

TECHNICAL MANUAL

**ORGANIZATIONAL,
DIRECT SUPPORT, AND
GENERAL SUPPORT MAINTENANCE
REPAIR PARTS AND SPECIAL TOOLS LIST
(INCLUDING DEPOT MAINTENANCE REPAIR PARTS)**

FOR

**BRIDGE, ARMORED-VEHICLE LAUNCHED:
SCISSORING TYPE
CLASS 60 (5420-00-522-9599)
AND CLASS 70 (5420-01-390-3933)
ALUMINUM, 60 FOOT SPAN;
FOR USE WITH M48 AND M60 LAUNCHER
(ALL MAKES AND MODELS)**

APPROVED FOR PUBLIC RELEASE, DISTRIBUTION IS UNLIMITED.

CHANGE
NO. 1

HEADQUARTERS
DEPARTMENT OF THE ARMY
Washington D.C. ,. 10 February 1997

ORGANIZATIONAL
DIRECT SUPPORT, AND
GENERAL SUPPORT MAINTENANCE
REPAIR PARTS AND SPECIAL TOOLS LIST
(INCLUDING DEPCOT MAINTENANCE REPAIR PARTS)
FOR
BR:DGE, ARMORED-VEHICLE LAUNCHED:
SCISSORING TYPE
CLASS 60 (5420-00-522-9599)
AND CLASS 70 (5420-01-390-3933)
ALUMINUM 60 FOOT SPAN;
FOR USE WITH M48 AND M60 LAUNCHER
(ALL MAKES AND MODELS)

TM 5-5420-203-24P, dated 8 November 1988, is changed as follows:

1. Remove old pages and -insert new pages.
2. New or changed text is :indicated by a vertical bar in the margin of the page.
3. Added or revised 1llustrat:ons are indicated by a hand pointing toward new item number.
4. Title and distribution restriction statement has changed.

Remove Pages	Insert Pages	Remove Pages	Insert Pages
Page i	Page i	Page 6-1	Page 6-1
Page ii	Page ii	Figure 7	Figure 7
Page 1-1	Page 1-1	Page 7-1	Page 7-1
Figure 2	Figure 2	Page 7-2	Page 7-2
Page 2-1	Page 2-1	Page 8-1	Page 8-1
Figure 3	Figure 3	Page 8-2	Page 8-2
Page 3-1	Page 3-1	Page 9-1	Figure 9
Figure 4	Figure 4		Page 9-1
Page 4-1	Page 4-1		
Figure 5	Figure 5		
Page 5-1	Page 5-1	Pages 1-1-1-13	Pages 1-1-1-14
Figure 6	Figure 6	Front Cover	Front Cover

File this change in front of the publication for reference purposes.

Approved for public release; distribution is unlimited.

By Order of the Secretary of the Army:

Official:

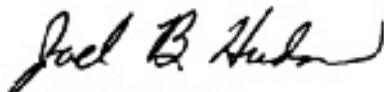

JOEL B. HUDSON
*Administrative Assistant to the
Secretary of the Army*
02935

DENNIS J. REIMER
*General, United States Army
Chief of Staff*

DISTRIBUTION:

To be distributed in accordance with the initial distribution number (IDN) 371233, requirements for TM 5-5420-203-24P.

ORGANIZATIONAL,
DIRECT SUPPORT, AND
GENERAL SUPPORT MAINTENANCE
REPAIR PARTS AND SPECIAL TOOLS LIST
(INCLUDING DEPOT MAINTENANCE REPAIR PARTS)
FOR
BRIDGE, ARMORED-VEHICLE LAUNCHED:
SCISSORING TYPE
CLASS 60 (5420-00-522-9599)
AND CLASS 70 (5420-01-390-3393)
ALUMINUM 60 FOOT SPAN;
FOR USE WITH M48 AND M60 LAUNCHER
(ALL MAKES AND MODELS)

Current as of 15 July 1996

Approved for public release, distribution is unlimited.

REPORTING OF ERRORS AND RECOMMENDING IMPROVEMENTS

You can help improve this manual. If you find any mistakes or if you know of a way to improve the procedures, please let us know. Mail your letter, DA Form 2028 (Recommended Changes to Publications and Blank Forms), or DA Form 2028-2 located at the back of this manual direct to: Commander, US Army Tank-automotive and Armaments Command, ATTN: AMSTA-IM-OPIT, Warren, MI 48397-5000. A reply will be furnished to you. You may also provide DA Form 2028-2 information to TACOM via datafax or e-mail. TACOM's datafax number for AMSTA-IM-OPIT is (810) 574-6323 and the e-mail address is amsta-im-opit~cc.tacom-tech-pubs@cc.tacom.army.mil.

TABLE OF CONTENTS

	PAGE	ILLUS/ FIGURE
SECTION I. INTRODUCTION	1	
SECTION II. REPAIR PARTS LIST	1-1	
GROUP		
01 HYDRAULIC SYSTEM.....	1-1	
01 HYDRAULIC LINES, CYLINDER, AND FITTINGS.....	1-1	1
0101 HYDRAULIC CYLINDER COMPONENTS (ASSY P/N 13211E7880	2-1	2

TABLE OF CONTENTS - Continued

GROUP		PAGE	ILLUS/ FIGURE
0102	SCISSORING CYLINDER PIN AND COMPONENT.....	1-1	1
02	FRAME	3-1	3
02	BEAMS, CABLES, AND RELATED PARTS.....	3-1	3
02	CENTER PANELS AND RELATED PARTS	4-1	4
02	END PANELS AND RELATED PARTS.....	5-1	5
02	DIAPHRAGM AND RELATED PARTS.....	6-1	6
0201	CENTER PANEL COMPONENTS (ASSY P/N 13211E7825 FEMALE).....	7-1	7
0202	CENTER PANEL COMPONENTS ASSY P/N 13211E7813 MALE)	7-1	7
0203	QUADRANT ASSEMBLY AND COMPONENTS.....	4-1	4
0204	END PANEL COMPONENTS (ASSY P/N 13211E7843 FEMALE).....	8-1	8
0205	END PANEL COMPONENTS (ASSY P/N 1321 1E7837 MALE)	8-1	8
0206	RAMP TIE ROD ASSEMBLY AND COMPONENTS.....	5-1	5
0207	QUICK DISCONNECT AND COMPONENTS.....	6-1	6
020701	QUICK DISCONNECT BRACKET AND COMPONENTS.....	6-1	6
03	FRAME	9-1	9
03	MLC 70 AVLB.....	9-1	9
SECTION III.	SPECIAL TOOLS LIST	10-1	10
2604	SPECIAL TOOLS MULTIPLE LEG SLING	10-1	10
SECTION IV.	CROSS-REFERENCE INDEXES	I-1	
	NATIONAL STOCK NUMBER INDEX	I-1	
	PART NUMBER INDEX	I-4	
	FIGURE AND ITEM NUMBER INDEX	I-10	

ORGANIZATIONAL
DIRECT SUPPORT, AND
GENERAL SUPPORT MAINTENANCE
REPAIR PARTS AND SPECIAL TOOLS LIST
SECTION I INTRODUCTION

1. Scope.

This RPSTL lists and authorizes spares, repair parts required for performance of organizational, direct support, and general support maintenance of the Bridge. It authorizes the requisitioning, issue, and disposition of spares, repair parts and special tools as indicated by the Source, Maintenance, and Recoverability (SMR) codes.

2. General.

In addition to Section I, Introduction this Repair Parts and Special Tools List is divided into the following sections:

a. Section II. Repair Parts List. A list of spares and repair parts authorized by this RPSTL for use in the performance of maintenance. The list also includes parts which must be removed for replacement of the authorized parts. Parts lists are composed of fictional groups in ascending alphanumeric sequence, with the parts in each group listed in ascending figure and item number sequence. Items listed are shown on the associated illustration(s)/ figure(s).

b. Section III. Special Tools List. Not applicable.

c. Section IV. Cross-reference Index. A list, in National Item Identification Number (NIIN) sequence, of all National stock numbered items appearing in the listing, followed by a list in alphanumeric sequence of all part numbers appearing in the listings. National stock numbers and part numbers are cross-referenced to each illustration figure and item number appearance. The figure and item number index lists figure and item numbers in alphanumeric sequence and cross-reference NSN, FSCM and part numbers.

3. Explanation of Columns (Section II).

a. ITEM NO. (Column (1)). Indicates the number used to identify items called out in the illustration

b. SMR CODE (Column (2)) The Source, Maintenance, and Recoverability (SMR) code is a 5-position code containing supply/ requisitioning information, maintenance level authorization criteria, and disposition instruction, as shown in the following breakout

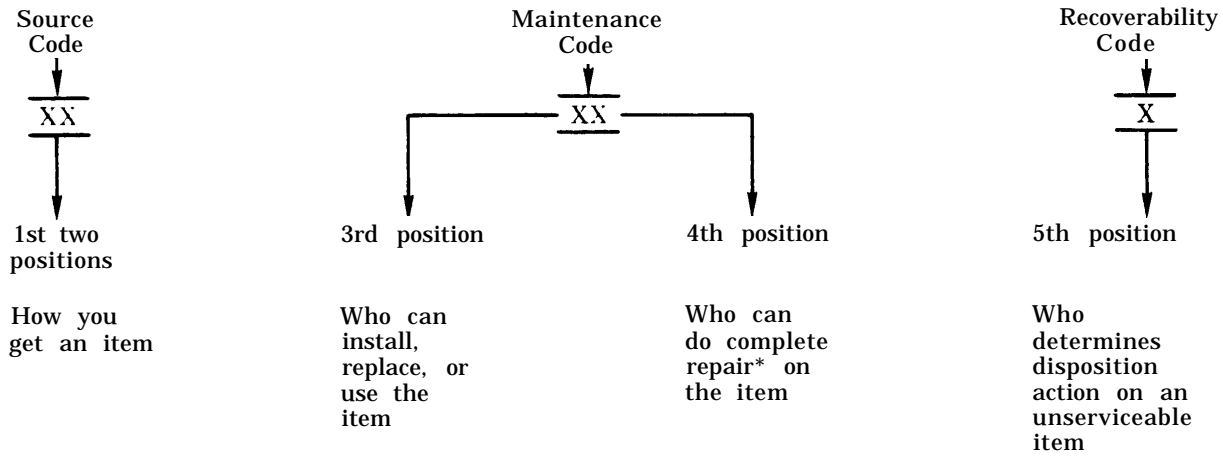

*Complete Repair Maintenance capacity, capability, and authority to perform all corrective maintenance tasks of the "Repair" function in a use/user environment in order to restore serviceability to a failed item.

(1) Source Code. The source code tells you how to get an item needed for maintenance, repair, or overhaul of an end item/equipment. Explanations of source codes follow:

Code	Explanation
PA PB PC** PD PE PF PG	Stocked items; use the applicable NSN to request/requisition items with these source codes. They are authorized to the level indicated by the code entered in the 3rd position of the SMR code. ** NOTE Items coded PC are subject to deterioration
KD KF KB	Items with these codes are not to be requested/requisitioned individually. They are part of a kit which is authorized to the maintenance level indicated in the 3rd position of the SMR code. The complete kit must be requisitioned and applied.
MO - (Made at Org Level) MF - (Made at DS Level) MH - (Made at GS Level) MD - (Made at Depot):)	Items with these codes are not to be requested/requisitioned individually. They must be made from bulk material which is identified by the part number in the DESCRIPTION AND USABLE ON CODE (UOC) column and listed in the Bulk Material group of the repair parts list in this RPSTL. If the item is authorized to you by the 3rd position code of the SMR code, but the source code indicates it is made at a higher level, order the item from the higher level of maintenance.

Code	Explanation
------	-------------

AO - (Assembled by Org Level)
AF - (Assembled by DS Level)
AH - (Assembled by GS Level)
AD - (Assembled by Depot)

Items with these codes are not to be requested/requisitioned individually. The parts that make up the assembled item must be requisitioned or fabricated and assembled at the level of maintenance indicated by the source code. If the 3rd position code of the SMR code authorizes you to replace the item, but the source code indicates the item is assembled at a higher level, order the item from the higher level of maintenance.

XA - Do not requisition an "XA" -coded item. Order its next higher assembly. (Also, refer to the NOTE below).

XB - If an "XB" item is not available from salvage, order it using the FSCM and part number given.

XD - Item is not stocked. Order an "XD" -coded item through normal supply channels using the FSCM and part number given, if no NSN is available.

NOTE Cannibalization or cent rolled exchange, when authorized, may be used as a source of supply for items with the above source codes, except for those source coded "XA".

(2) Maintenance Code. Maintenance codes tell you the level(s) of maintenance authorized to USE and REPAIR support items. The maintenance codes are entered in the third and fourth positions of the SMR Code as follows:

(a) The maintenance code entered in the third position tells you the lowest maintenance level authorized to remove, replace, and use an item. The maintenance code entered in the third position will indicate authorization to one of the following levels of maintenance.

Code	Application/Explanation
------	-------------------------

C - Crew or operator maintenance done within organizational maintenance.

O - Organizational level can remove, replace, and use the item.

F - Direct support level can remove, replace, and use the item.

H - General support level can remove, replace, and use the item.

D - Depot level can remove, replace, and use the item.

(b) The maintenance code entered in the fourth position tells whether or not the item is to be repaired and identifies the lowest maintenance level with the capability to do complete repair (i.e., perform all authorized repair functions). (NOTE: Some limited repair may be done on the item at a lower level of maintenance, if authorized by the Maintenance Allocation Chart (MAC) and SMR codes.) This position will contain one of the following maintenance codes.

Code	Application/ Explanation
O	Organizational is the lowest level that can do complete repair of the item.
F	Direct support is the lowest level that can do complete repair of the item.
H	General support is the lowest level that can do complete repair of the item.
D	Depot is the lowest level that can do complete repair of the item.
Z	Nonreparable. No repair is authorized.
B	No repair is authorized. (No parts or special tools are authorized for the maintenance of a "B" coded item.) However, the item may be reconditioned by adjusting, lubricating, etc., at the user level.

(3) Recoverability Code. Recoverability codes are assigned to items to indicate the disposition action on unserviceable items. The recoverability code is entered in the fifth position of the SMR Code as follows:

Recoverability Codes	Application/Explanation
Z	Nonreparable item. When unserviceable, condemn and dispose of the item at the level of maintenance shown in 3rd position of SMR Code.
O	Reparable item. When uneconomically repairable, condemn and dispose of the item at organizational level.
F	Reparable item. When uneconomically repairable, condemn and dispose of the item at the direct support level.
H	Reparable item. When uneconomically repairable, condemn and dispose of the item at the genera 1 support level.
D	Reparable item. When beyond lower level repair capability, return to depot. Condemnation and disposal of item not authorized below depot level.
A	Item requires special handling or condemnation Procedures because of specific reasons (e.g., precious metal content, high dollar value, critical material, or hazardous material). Refer to appropriate manuals/directives for specific instructions.

c. FSCM (Column(3)). The Federal Supply Code for Manufacturer (FSCM) is a 5-digit numeric code which is used to identify the manufacturer, distributor, or Government agency, etc., that supplies the item.

d. PART NUMBER (Column (4)). Indicates the primary number used by the manufacturer (individual, company, firm, corporation or Government activity), which controls the design and characteristics of the item by means of its engineering drawings, specifications standards, and inspection requirements to identify an item or range of items.

NOTE When you use an NSN to requisition an item, the item you receive may have a different part number from the part ordered.

e. DESCRIPTION AND USABLE ON CODE (UOC) (Column (5)). This column includes the following information

- (1) The Federal item name and, when required, a minimum description to identify the item.
- (2) The physical security classification is not applicable.
- (3) Kits and sets are not applicable.
- (4) Spare/ repair parts that make up an assembled item are listed immediately following the assembled line item entry.
- (5) Part numbers for bulk materials are not applicable.
- (6) Serial number effectivity is not applicable.
- (7) The usable on code is not applicable.
- (8) Basis of issue (BOI) is not applicable.
- (9) The statement "END OF FIGURE" appears just below the last item description in Column 5 for a given figure in Section II.

f. QTY (Column (6)). The QTY Quantity per figure column indicates the quantity of the item used in the breakout shown on the illustration figure, which is prepared for a fictional group, subfunctional group, or an assembly. A "V" appearing in this column in lieu of a quantity indicates that the quantity is variable and the quantity may vary from application to application.

4. Explanation of Columns (Sect. IV).

a. NATIONAL STOCK NUMBER (NSN) INDEX.

(1) STOCK NUMBER column. This column lists the NSN by National Item Identification Number (NIIN) sequence. The NIIN consists of the last nine digits of the NSN, i.e.:

NSN 5305-01-674-1467 NIIN 5305-01-674-1467

When using this column to locate an item, ignore the first 4 digits of the NSN. However, the complete NSN should be used when ordering items by the stock number.

(2) FIG. column. This column lists the number of the figure where the item is identified/located. The figures are in numerical order in Section II.

(3) ITEM column. The item number identifies the item associated with the figure listed in the adjacent FIG. column. This item is also identified by the NSN listed on the same line.

b. PART NUMBER INDEX. Part numbers in this index are listed by part number in ascending alphanumeric sequence (i.e., vertical arrangement of letter and number combination which places the first letter or digit of each group in order A through Z, followed by the numbers 0 through 9 and each following letter or digit in like order).

(1) FSCM column. The Federal Supply Code for Manufacturer (FSCM) is a 5-digit numeric code used to identify the manufacturer, distributor, or Government agency, etc., that supplies the item.

(2) PART NUMBER column. Indicates the primary number used by the manufacturer (individual, firm, corporation, or Government activity), which controls the design and characteristics of the item by means of its engineering drawings, specifications standards, and inspection requirements to identify an item or range of items.

(3) STOCK NUMBER column. This column lists the NSN for the associated part number and manufacturer identified in the PART NUMBER and FSCM columns to the left.

(4) FIG. column. This column lists the number of the figure where the item is identified/located in Section II.

(5) ITEM column. The item number is that number assigned to the item as it appears in the figure referenced in the adjacent figure number column.

c. FIGURE AND ITEM NUMBER INDEX.

(1) FIG. column. This column lists the number of the figure where the item is identified/located in Section II.

(2) ITEM column. The item number is that number assigned to the item as it appears in the figure referenced in the adjacent figure number column.

(3) STOCK NUMBER column. This column lists the NSN for the item.

(4) FSCM column. The Federal Supply Code for Manufacturer (FSCM) is a 5-digit numeric code used to identify the manufacturer, distributor, or Government agency, etc., that supplies the item.

(5) PART NUMBER column. Indicates the primary number used by the manufacturer (individual, firm, corporation, or Government activity), which controls the design and characteristics of the item by means of its engineering drawings, specifications standards, and inspection requirements to identify an item or range of items.

5. Special Information

a. USABLE ON CODE. Not applicable.

b. FABRICATION INSTRUCTIONS. Not applicable.

c. ASSEMBLY INSTRUCTIONS. Detailed assembly instructions for items source coded to be assembled from component spare/ repair parts are found in TM5-5420-203-14. Items that make up the assembly are listed immediately following the assembly item entry or reference is made to an applicable figure.

d. KITS. Not applicable.

e. INDEX NUMBERS. Not applicable.

f. ASSOCIATED PUBLICATIONS.

The following publications pertain to the Bridge and its components.

<u>Publication</u>	<u>Short Title</u>
TM 5-5420-203-14	Bridge, Armored-Vehicle Launched

g. ILLUSTRATIONS - LISTING. Not applicable.

h. ITEMS IN PARENTHESES. Item numbers appearing in parentheses, i.e., (8), signify components that are supplied only as part of the item having the same number or indicate continuation of an item.

i. FIGURE ASSEMBLY PART NUMBER. The next higher assembly part number for component parts listed is shown in parentheses.

EXAMPLE: (ASSY P/N 13211E7880)

j. CHANGE PAGE INFORMATION. An asterisk in the left hand margin (before the item number) indicates a change has occurred in at least one of the columns for that item.

6. How to Locate Repair Parts.

a. When National Stock Number or Part Number is Not Known.

(1) First. Using the table of contents, determine the assembly group or subassembly group to which the item belongs. This is necessary since figures are prepared for assembly groups and subassembly groups, and listings are divided into the same groups.

(2) Second. Find the figure covering the assembly group or subassembly group to which the item belongs.

(3) Third. Identify the item on the figure and use the Figure and Item Number Index to find the NSN.

b. When National Stock Number or Part Number is Known

(1) First. Using the National Stock Number or the Part Number index find the pertinent National Stock Number or Part Number. The NSN index is in National Item Identification Number (NIIN) sequence (see 4a. (1)). The part numbers in the Part Number index are listed in ascending alphanumeric sequence (see 4.b.). Both indexes cross-reference you to the illustration figure and item number of the item you are looking for.

(2) Second. Turn to the figure and item number, verify that the item is the one you are looking for, then locate the item number in the repair parts list for the figure.

7. Abbreviations.

<u>Abbreviations</u>	<u>Explanations</u>
P/N	Part Number
RPSTL	Repair Parts and Special Tools List

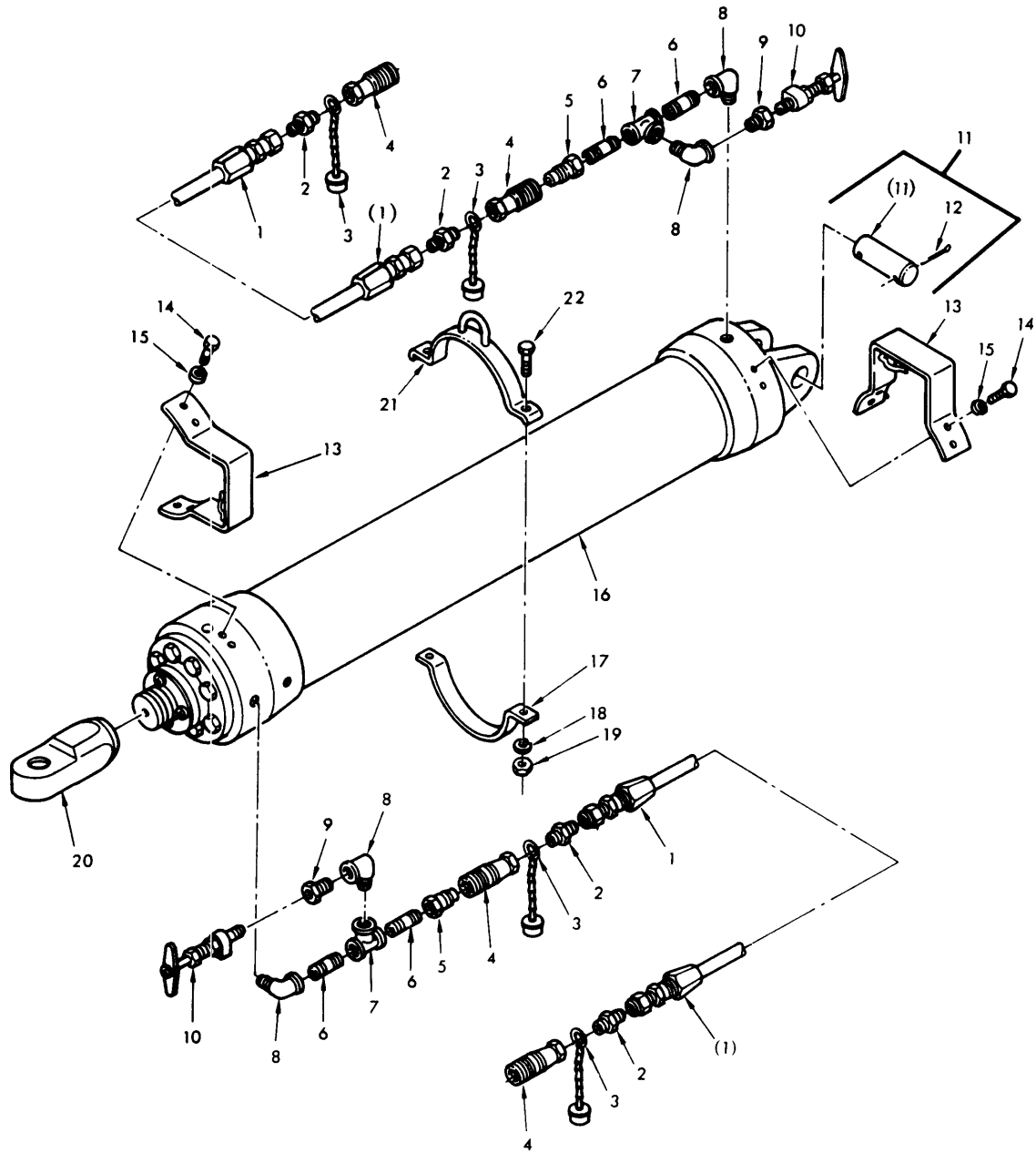
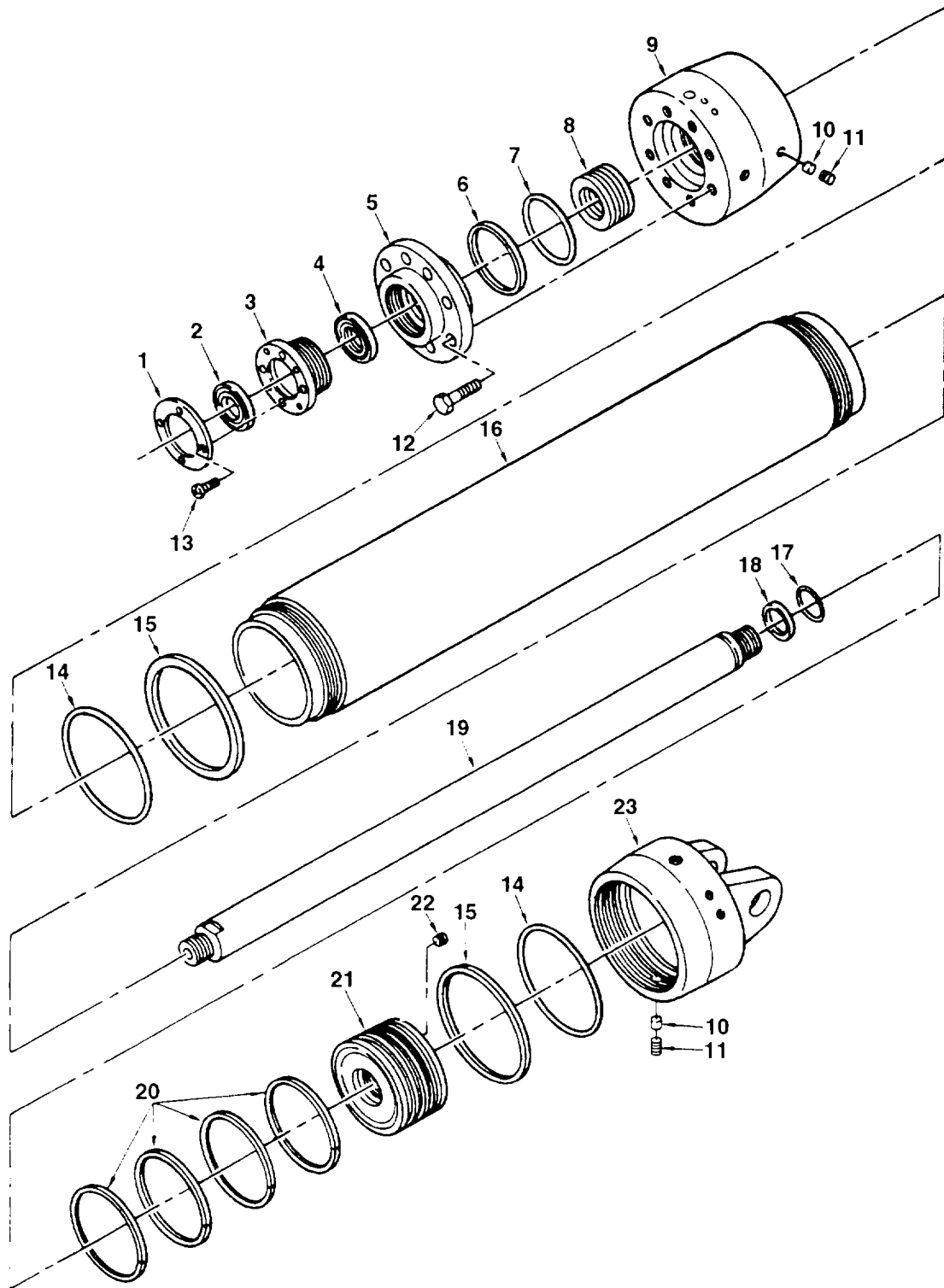

FIGURE 1. HYDRAULIC LINES, CYLINDER, AND FITTINGS

(1) ITEM NO	SECTION II (2) SMR CODE	(3) NSN	(4) CAGEC	TM 5-5420-203-24P C01 (5) PART NUMBER	(6) DESCRIPTION AND USABLE ON CODES (UDC)	(7) QTY
GROUP 01: HYDRAULIC SYSTEM						
FIG. 1 HYDRAULIC LINES. CYLINDER. AND FITTINGS						
1	PAOZZ	4720-00-732-3418	97403	1321 1E7904-3	HOSE ASSEMBLY, RUBBE	2
2	PAOZZ	4730-00-202-8469	96906	MS51500A12	ADAPTER STRAIGHT, PI	4
3	PAOZZ	5420-00-816-5649	97403	13211E7831	CAP ASSEMBLY HYDRAU	4
4	PAOZZ	4730-00-257-0236	97403	13211E3213	COUPLING HALF, QUICK.....	4
5	PAOZZ	4730-00-182-9086	97403	13211 E3212	COUPLING HALF, QUICK.....	2
6	PAOZZ	4730-00-277-9457	81348	WWN351TYPEB	PIPE	4
7	PAOZZ	4730-01-009-0981	81343	12-12-140438S	TEE. PIPE	2
8	PAOZZ	4730-00-203-0030	81343	12-12-140239C	ELBOW, PIPE	4
9	PAOZZ	4730-00-278-3917	81343	12-4-140140C	PIPE FITTING	2
10	PAOZZ	4820-00-249-4203	97403	1321 1E7842	VALVE, ANGLE	2
11	PBOOO	5420-00-542-3157	97403	13211E7873	PIN, CYLINDER, SCISSO (GROUP 0102)	1
12	PAOZZ	5315-00-597-7399	96906	MS24665-631	PIN, COTTER.....	2
13	PBOZZ	5420-00-182-8639	97403	13211E7892	SHIELD ASSEMBLY.....	2
14	PZOZZ	5305-00-226-7767	96906	MS90726-109	SCREW, CAP, HEXAGON H.....	8
15	PAOZZ	5310-00-584-5272	96906	MS35338-48	WASHER. LOCK	8
16	PAOFD	5420-01-104-9108	97403	13211E7880	CYLINDER. HYDRAULIC (FOR 1.....	1
COMPONENT PARTS SEE GROUP 0101)						
17	PAOZZ	5340-01-145-1968	97403	13211E7939	STRAP. RETAINING, LOWER	1
18	PAOZZ	5310-00-584-7888	96906	MS35338-51	WASHER. LOCK	2
19	PAOZZ	5310-00-763-8921	96906	MS51967-23	NUT, PILAIN. HEXAGON	2
20	PBOZZ	5420-00-542-3156	97403	1321 1E7874	CLEVIS, CYLINDER. SCI.....	1
21	PBOZZ	5420-00-542-3192	97403	13211E7935	BRACKET ASSEMBLY, UPPER	1
22	PAOZZ	5305-00-947-4353	96906	MS90728-190	SCREW, CAP, HEXAGON H.....	2

END OF FIGURE



SB002

FIGURE 2. HYDRAULIC CYLINDER COMPONENTS
(ASSY P/N 13211E7880)

SECTION II				TM 5-5420-203-24P C01		
(1)	(2)	(3)	(4)	(5)	(6)	(7)
ITEM NO	SMR CODE	NSN	CAGEC	PART NUMBER	DESCRIPTION AND USABLE ON CODES (UDC)	QTY
GROUP 0101						
FIG. 2 HYDRAULIC CYLINDER COMPONENTS (ASSY P/N 13211 E7880)						
1	PAFZZ	5420-01-121-1549	97403	13211E7871	PLATE, RETAINING. SHA.....	1
2	PAFZZ	1650-00-516-8336	96906	MS28776M2-41	RING, WIPER	1
3	PAFZZ	5365-00-689-3127	97403	13211E7868	BUSHING, CYLINDER	1
4	PAFZZ	2590-00-606-4474	97403	13211E3144-4	RING. WIPER	1
5	PBFZZ	5420-01-045-3562	97403	13214EC033	FLANGE, LAND RING	1
6	PAFZZ	5330-00-883-0233	96906	MS27595-441	SPACER. RING	1
7	PAFZZ	5330-00-579-9675	96906	MS28775-441	PACKING, PREFORMED	1
8	PAFZZ	5330-00-450-6605	97403	1321 11E3142-4	PACKING ASSEMBLY	1
9	PADZZ	5420-00-235-4684	97403	13211E7876	CYLINDER HEAD. LAUNC.....	2
10	PADZZ	5340-00-872-7696	97403	13211E3147	PLUG, PROTECTIVE. DUS.....	2
11	PADZZ	5305-01-038-8424	97403	13211 IE7880-8	SETSCREW	2
12	PAFZZ	5305-00-904-4004	96906	MS90727-209	SCREW, CAP. HEXAGON H.....	8
13	PAFZZ	5305-00-993-1849	96906	MS35207-259	SCREW, MACHINE	4
14	PADZZ	5330-00-618-4602	96906	MS28775-451	PACKING, PREFORMED	2
15	PADZZ	5330-01-121-2778	96906	MS27595-451	RETAINER. PACKING.....	2
16	PADZZ	5420-00-449-7172	97403	13214E0023-4	CYLINDER, ACTUATING	1
17	PADZZ	5330-00-729-6632	96906	MS28775-244	PACKING, PREFORMED	1
18	PADZZ	5330-01-128-5202	96906	MS27595-244	RETAINER, PACKING.....	1
19	PBDZZ	5420-00-186-3405	97403	1321 IE7867	ROD. PISTON, LINEAR A	1
20	PADZZ	2805-00-606-4396	97403	1321 IE3121-4	RING PISTON	4
21	PADZZ	5420-01-120-3020	97403	13214E0025-2	PISTON, BRIDGE, LAUNC.....	1
22	PADZZ	5305-00-724-7875	96906	MS51966-8	SETSCREW	1
23	PADZZ	5420-01-121-1608	97403	13211E7875	HEAD, LINEAR ACTUATI.....	1

END OF FIGURE

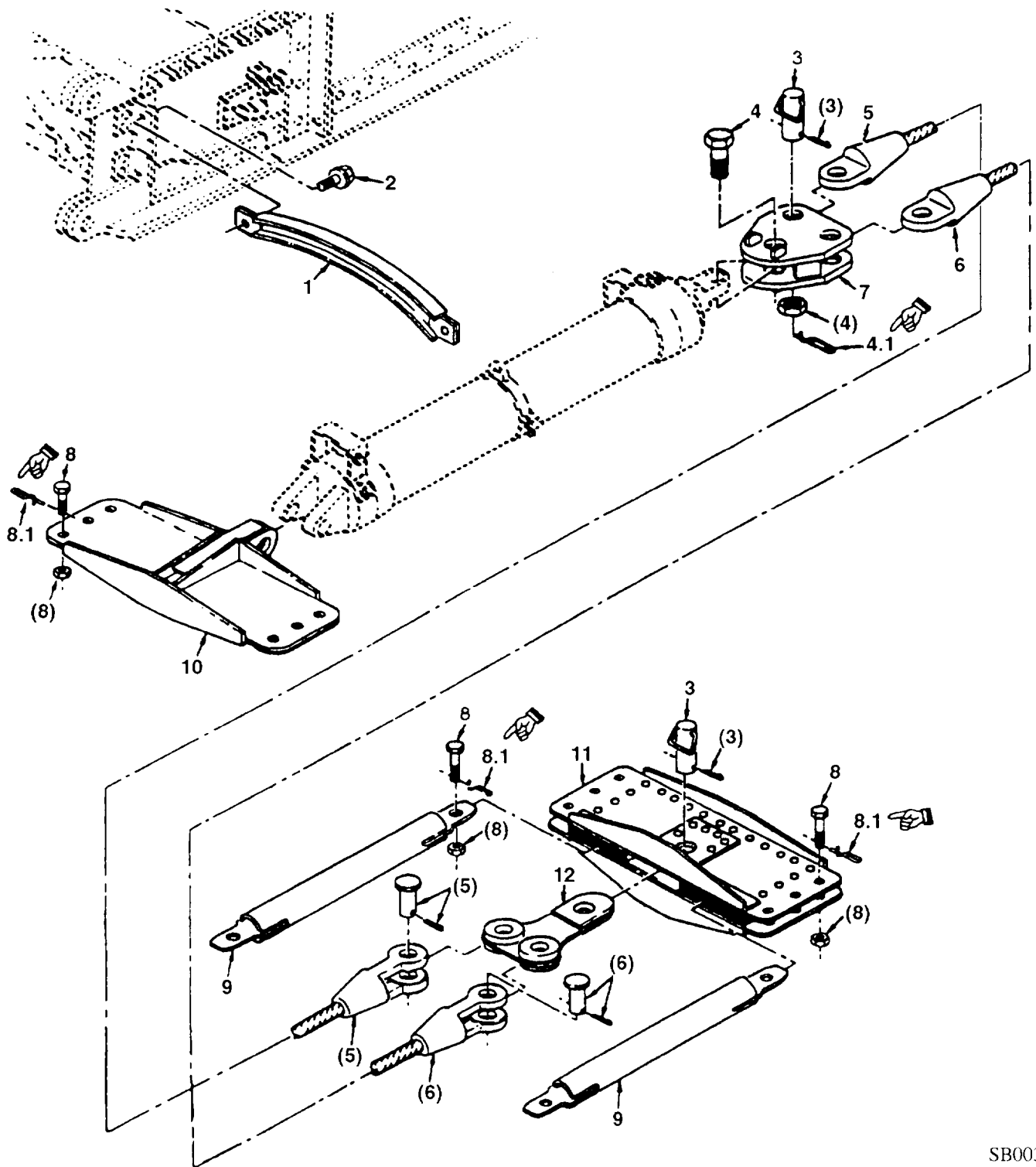

FIGURE 3. BEAMS, CABLES, AND RELATED PARTS

(1) ITEM NO	SECTION II (2) SMR CODE	(3) NSN	(4) CAGEC	TM 5-5420-203-24P C01 (5) PART NUMBER	(6) DESCRIPTION AND USABLE ON CODES (UDC)	(7) QTY
GROUP 02: FRAME						
FIG. 3 BEAMS, CABLES, AND RELATED PARTS						
1	PBOZZ	5420-00-542-3151	97403	13211E7851	SUPPORT, CYLINDER	2
2	PAOZZ	5306-00-542-3126	97403	13211E7898	BOLT, ASSEMBLED WASH	4
3	PBOZZ	5420-00-542-3137	97403	13211E7890	PIN, EQUALIZER PLATE	2
4	PAOZZ	5420-00-542-3143	97403	13211E7931	BOLT, SOCKET	2
4.1	PAOZZ	5420-00-060-7032	81349	MIL452243	PIN, RETAINING, 7 13/16" LONG	2
5	PAOZZ	5420-00-542-3141	97403	13211E7893	CABLE, QUADRANT	1
6	PAOZZ	5420-00-542-3140	97403	13211E7903	CABLE, SCISSORING L.....	1
7	PBOZZ	5420-00-542-3138	97403	13211E7883	PLATE, EQUALIZER	1
8	PAOZZ	5420-00-542-3145	97403	13211E7926	BOLT, BRIDGE.....	16
8.1	PAOZZ	5420-00-060-7031	81349	MILR52243	PIN, RETAINING, 4 1/8" LONG	16
9	PBOZZ	5420-00-542-3139	97403	13211E7882	STRUT, QUADRANT	2
10	PBOZZ	5420-00-542-3148	97403	13211E7884	BEAM, CYIINDER	1
11	PBOZZ	5420-00-542-3146	97403	1321 1E7885	BEAM, CABLE.....	1
12	PBOZZ	5420-00-542-3147	97403	1321 1E7881	PLATE, EQUALIZER	1
END OF FIGURE						

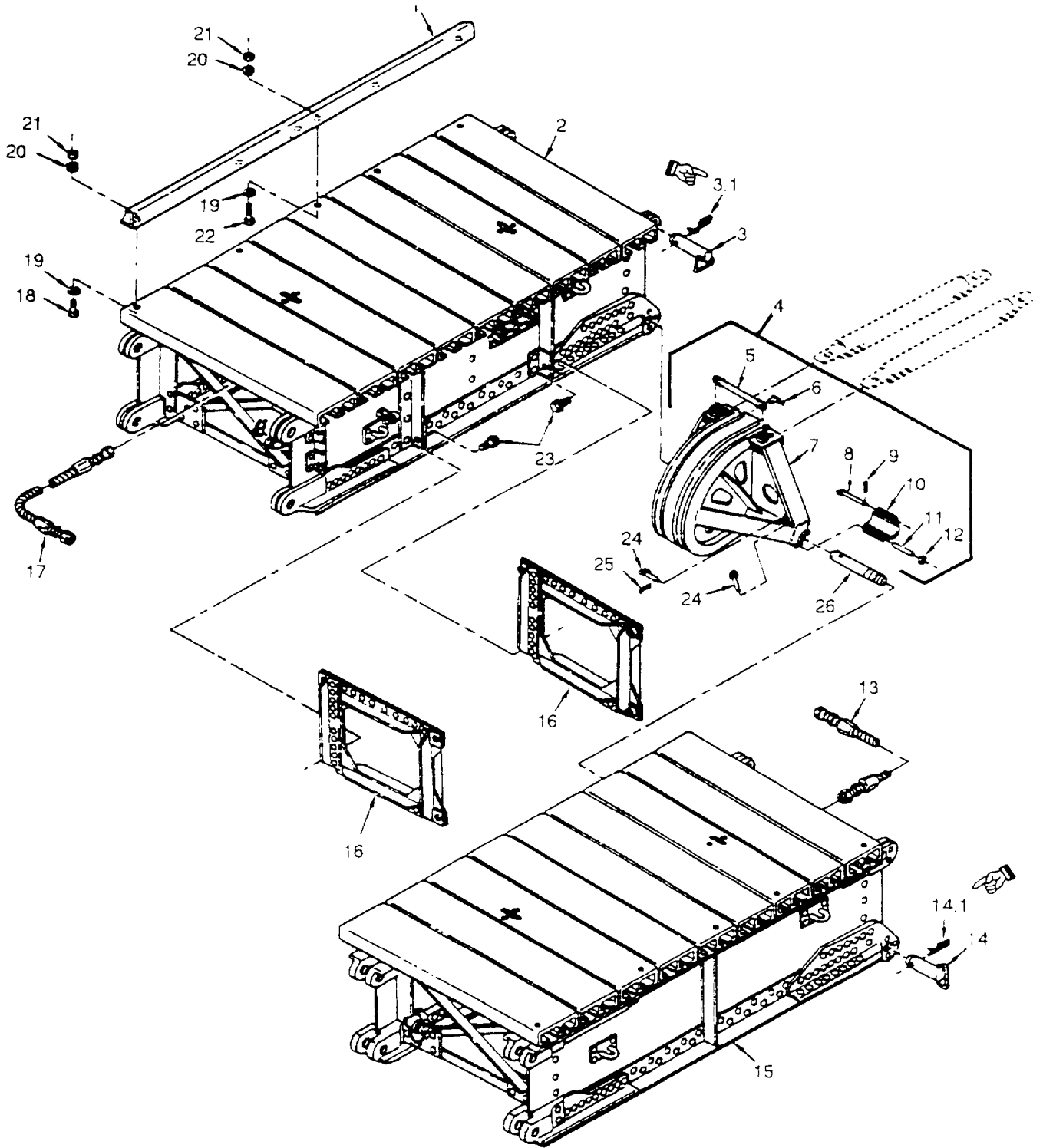

FIGURE 4. CENTER PANELS AND RELATED PARTS

(1) ITEM NO	SECTION II (2) SMR CODE	(3) NSN	(4) CAGEC	TM 5-5420-203-24P C01 (5) PART NUMBER	(6) DESCRIPTION AND USABLE ON CODES (UDC)	(7) QTY
GROUP 02: FRAME						
FIG. 4 CENTER PANELS AND RELATED PARTS						
1	PBOZZ	5420-00-542-3130	97403	13211E7858	CURB, DECK.....	4
2	PBOOD	5306-00-542-3115	97403	13211E7825	PANEL, CENTER, FEMALE (FOR.....	2
COMPONENT PARTS SEE GROUP 0201)						
3	PAOZZ	5420-00-542-3136	97403	13211E7820	PIN, CONNECTOR.....	4
3.1	PAOZZ	5420-00-060-7032	81349	MILR52243	PIN, RETAINING, 7 13/16" LONG	4
4	PAOOF	2520-00-240-8935	97403	1321 1E7860	QUADRANT ASSY, AVLB (GROUP 0203).....	1
5	PBOZZ	5420-00-542-3135	97403	13211E7861	RETAINER, CABLE	1
6	PAOZZ	5420-00-542-3134	97403	13211E7863	PIN, LOCKING, RETAINER.....	2
7	XAOZZ	5420-00-542-3132	97403	13211E7857	QUADRANT ASSY	1
8	PAOZZ	5420-00-542-3133	97403	13211E7862	PIN, LOCKING, QUADRAN	2
9	PAOZZ	5420-00-060-7030	97403	13217E9894	RETAINER, BRIDGE	2
10	XDOZZ	5420-01-109-5663	97403	13211E7934	HINGE, QUADRANT, AVLB.....	2
11	XDOZZ		97403	13211 E7860-5	PIN	2
12	XDOZZ	5310-00-809-8533	96906	MS27183-23	WASHER, FLAT	4
13	PAOZZ	4720-00-731-5332	98441	A1150-4	HOSE ASSEMBLY, NONME	2
14	PAOZZ	5420-00-682-4517	97403	13211E7891	PIN, PANEL, CENTER	2
14.1	PAOZZ	5420-00-060-7032	81349	MIL452243	PIN, RETAINING, 4 1/8" LONG	2
15	PBOOD	5420-00-542-3116	97403	13211E7813	PANEL, CENTER, MALE (FOR.....	2
COMPONENT PARTS SEE GROUP 0202)						
16	PBOZZ	5420-00-542-3123	97403	13211E7897	BRACE, TRANSVERSE	4
17	PAOZZ	4720-00-731-5333	98441	A1150-1	HOSE ASSEMBLY, NONME	4
18	PAOZZ	5305-00-922-7994	96906	MS90728-189	SCREW, CAP, HEXAGON H	8
19	PAOZZ	5310-00-167-0826	88044	AN960-1216	WASHER, FLAT	20
20	PAOZZ	5310-00-584-7888	96906	MS35338-51	WASHER, LOCK	20
21	PAOZZ	5310-00-763-8921	96906	MS51967-23	NUT, PLAIN, HEXAGON	20
22	PAOZZ	5305-00-947-4361	96906	MS90728-198	SCREW, CAP, HEXAGON H.....	12
23	PAOZZ	5306-00-542-3126	97403	1321 IE7898	BOLT, ASSEMBLED WASH	16
24	PAOZZ	5420-00-542-3133	97403	13211E7862	PIN, LOCKING, QUADRAN	4
25	PAOZZ	5420-00-061-2873	81349	MILR52243	RETAINER, BRIDGE PIN	2
26	PAOZZ	5420-00-542-3131	97403	13211E7913	PIN, HINGE, QUADRANT.....	2

END OF FIGURE

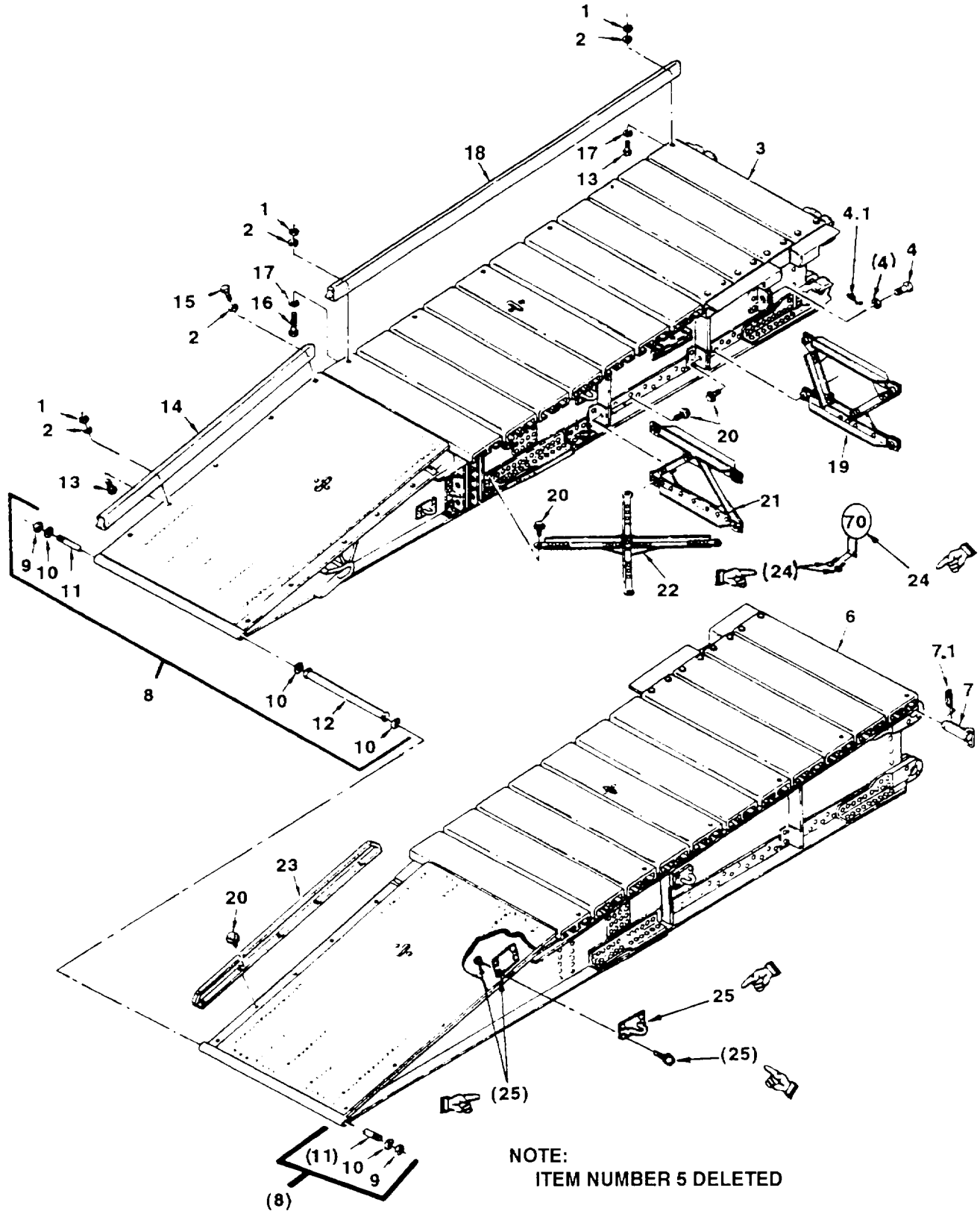
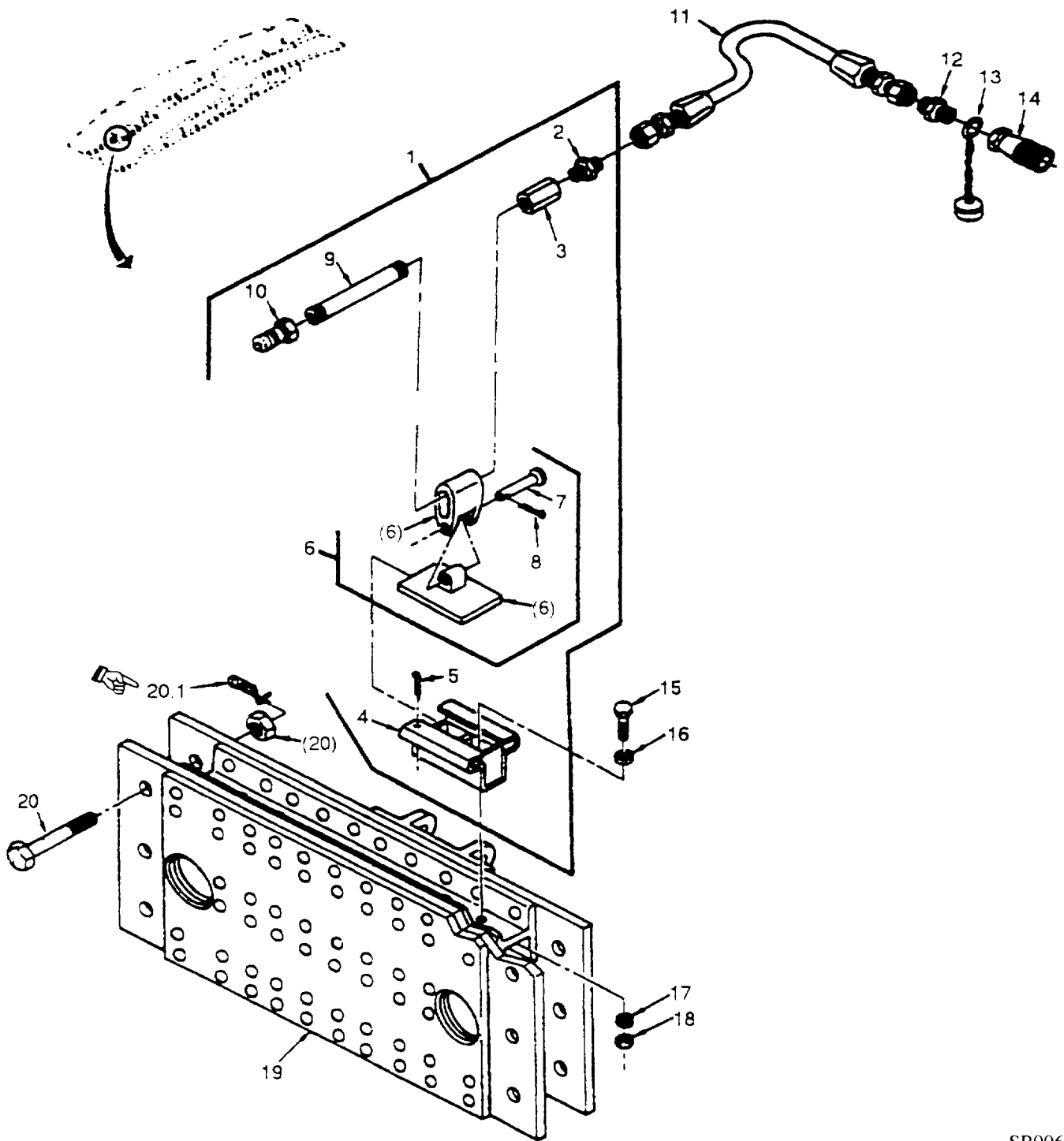

FIGURE 5. END PANELS AND RELATED PARTS

SECTION II				TM 5-5420-203-24P C01		
(1) ITEM NO	(2) SMR CODE	(3) NSN	(4) CAGEC	(5) PART NUMBER	(6) DESCRIPTION AND USABLE ON CODES (UDC)	(7) QTY
GROUP 02 FRAME						
FIG. 5 END PANELS AND RELATED PARTS						
1	PAOZZ	5310-00-763-8921	96906	MS51967-23	NUT, PLAIN. HEXAGON	40
2	PAOZZ	5310-00-584-7888	96906	MS35338-51	WASHER, LOCK	44
3	PBOOD	2510-00-542-3118	97403	13211E7843	PANEL ASSEMBLY, END. FEMALE (FOR COMPONENT PARTS SEE GROUP 0204)	2
4	PAOZZ	5420-00-542-3145	97403	13211E7926	BOILT, BRIDGE.....	2
4.1	PAOZZ	5420-00-060-7031	81349	MILR52243	PIN, RETAINING, 4 1/8" LONG	2
5	DELETED					
6	PBOOD	5420-00-542-3117	97403	13211E7837	PANEL, RAMP, MALE (FOR COMPONENT..... PARTS SEE GROUP 0205)	2
7	PAOZZ	5420-00-542-3136	97403	13211E7820	PIN. CONNECTOR.....	16
7.1	PAOZZ	5420-00-060-7032	81349	MIL452243	PIN, RETAINING, 7 13/16" LONG	16
8	PAOOO	5420-00-059-9809	97403	13211E7929	TIE ROD ASSY, RAMP (GROUP 0206)	2
9	PAOZZ	5310-01-032-2318	96906	MS51943-53	NUT, SELF-LOCKING, HE	2
10	PAOZZ	5310-00-983-8485	96906	MS27183-30	WASHER. FLAT	4
1	PFOZZ	5305-01-136-1186	97403	13211E7922	ROD, THREADED END.....	1
12	PBOZZ	5365-01-011-5038	97403	13211E7923	SPACER, RAMP.....	1
13	PAOZZ	5305-00-903-7298	96906	MS90725-189	SCREW. CAP, HEXAGON H.....	20
14	PBOZZ	5420-00-542-3129	97403	13211E7856	CURB, RAMP	4
15	PAOZZ	5305-00-050-4212	96906	MS90728-186	SCREW, CAP, HEXAGON H.....	4
16	PAOZZ	5305-00-947-4361	96906	MS90728-198	SCREW, CAP, HEXAGON H.....	20
17	PAOZZ	5310-00-167-0826	88044	AN960-1216	WASHER, FLAT	24
18	PBOZZ	5420-00-542-3128	97403	13211E7836	CURB, END PANEL	4
19	PBOZZ	5420-00-542-3124	97403	13211E7888	BRACE, TRANSVERSE	2
20	PAOZZ	5306-00-542-3126	97403	1321 1E7898	BOLT, ASSEMBLED WASH	44
21	PBOZZ	5420-00-542-3125	97403	13211E7887	BRACE, TRANSVERSE	2
22	PBOZZ	5420-00-542-3122	97403	132 1E7886	BRACE, LATERAL	2
23	PBOZZ	5420-00-542-3127	97403	13211E7899	CURB, INSIDE.....	4
END OF FIGURE						



SB006

FIGURE 6. DIAPHRAGM AND RELATED PARTS

(1) ITEM NO	SECTION II (2) SMR CODE	(3) NSN	(4) CAGEC	TM 5-5420-203-24P C01 (5) PART NUMBER	(6) DESCRIPTION AND USABLE ON CODES (UDC)	(7) QTY
GROUP 02: FRAME						
FIG 6 DIAPHRAGM AND RELATED PARTS						
1	AOOOO	4730-01-281-7903	903	13211E7849	QUICK DISCONNECT (GROUP 0207).....	4
2	PAOZZ	4730-00-202-8469	96906	MSS51500A12	ADAPTER. STRAIGHT PI	1
3	PAOZZ	4730-01-017-0264	97403	13211E7932	COUPLING, PIPE	1
4	PBOZZ	5420-00-542-3153	97403	13211E7854	HOLDER, BRACKET	1
5	PAOZZ	5315-00-298-1481	96906	MS24665-357	PIN. COTTER	1
6	PBOOO	5420-00-542-2115	97403	13211E7855	BRACKET, QUICK DISCO (GROUP 070701)	1
7	PAOZZ	5315-01-016-6654	97403	13211E7855-3	PIN. STRAIGHT., HEADED	1
8	PAOZZ	5315-00-839-5821	96906	MS24665-351	PIN. COTTER	1
9	PAOZZ	4730-01-169-2452	97403	13222E0986-3	NIPPLE. PIPE	2
10	PAOZZ	4730-00-182-9086	97403	1321E3212	COUPLING HALF, QUICK	1
11	PAOZZ	4720-00-986-6932	97403	132111-7904-2	HOSE ASSEMBLY, NONME	4
12	PAOZZ	4730-00-202-8469	96906	MS51500A112	ADAPTER. STRAIGHT. 11	4
13	PAOZZ	5420-00-816-5469	97403	132111E7831	CAP ASSEMBLY HYDRAULIC	4
14	PAOZZ	4730-00-257-0236	97403	13211E3213	COUPLING HALF. QUICK	4
15	PAOZZ	5305-00-732-0511	96906	M.S90728-110	SCREW, CAP, HEXAGON	8
16	PAOZZ	5310-00-809-5998	96906	MS27183-18	WASHER, FLAT	8
17	PAOZZ	5310-00-584-5272	96906	MS35338-48	WASHER. LOCK	8
18	PAOZZ	5310-01-070-2105	96906	NMS51967-14	NUT, PLAIN. HEXAGON	8
19	PBOZZ	5420-00-542-3149	97403	13211E7850	DIAPHRAGM. LAUNCHING	2
20	PBOZZ	5420-00-542-3144	97403	13211E7846	BOLT. DIAPHRAGM.....	2
20.1	PAOZZ	5420-00-060-7031	81349	MILR52243	PIN, RETAINING, 4 1/8" LONG	12

END OF FIGURE

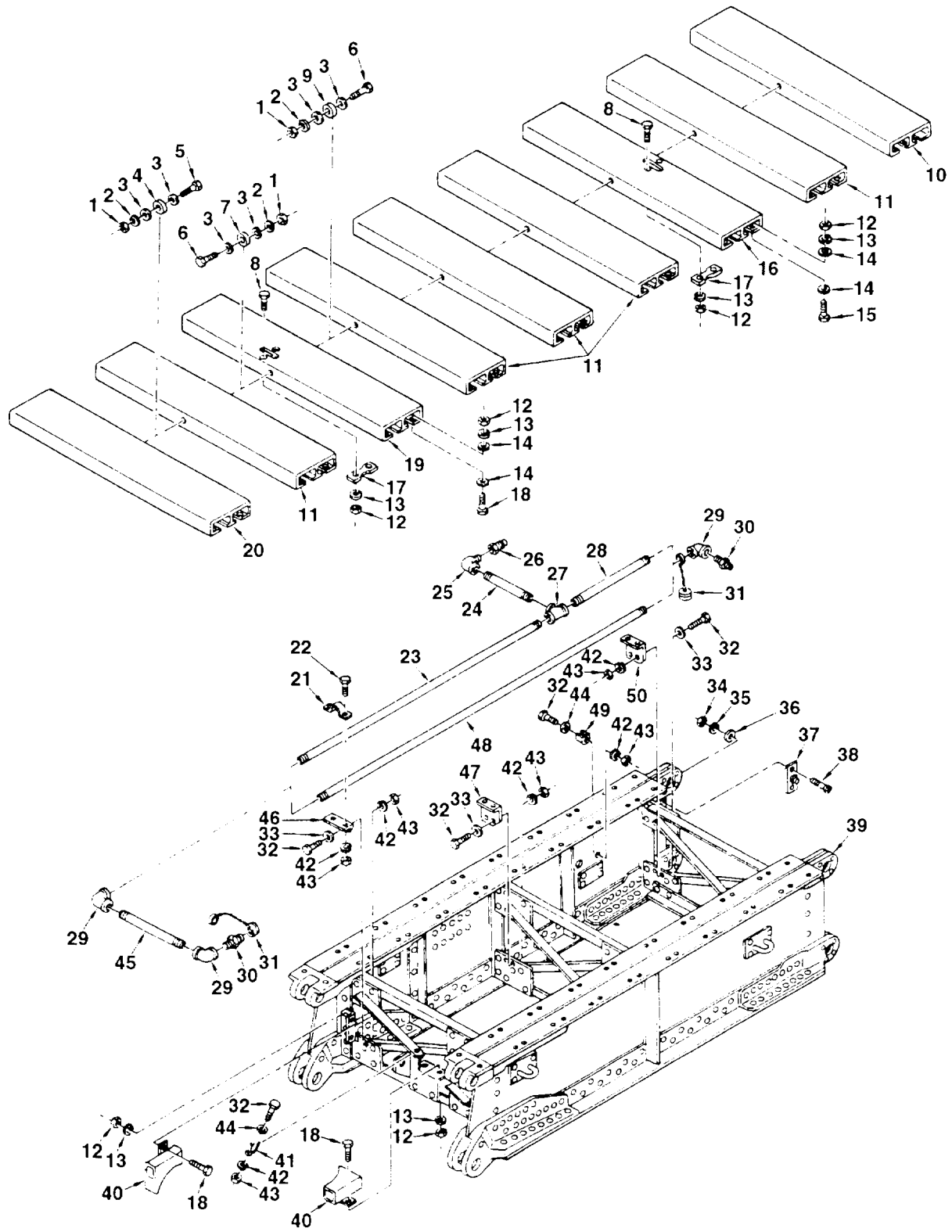

FIGURE 7 CENTER PANEL COMPONENTS
 (ASSY P/N'S 13211E7825 FEMALE
 AND 13211E7813 MALE)

(1) ITEM NO	SECTION II (2) SMR CODE	(3) NSN	(4) CAGEC	TM 5-5420-203-24P C01 (5) PART NUMBER	(6) DESCRIPTION AND USABLE ON CODES (UDC)	(7) QTY
GROUP 0201 AND 0202						
FIG. 7 CENTER PANEL COMPONENTS (ASSY P/N'S 13211E7825 FEMALE AND 13211E7813 MALE)						
1	PAOZZ	5310-00-763-8921	96906	MS51967-23	NUT, PLAIN, HEXAGON	8
2	PAOZZ	5310-00-584-7888	96906	MS35338-51	WASHER, LOCK	8
3	PBOZZ	5310-00-167-0826	88044	AN960-1216	WASHER, FLAT	16
4	PBOZZ	5365-01-128-5311	97403	13211E7852-3	SPACER, SLEEVE	2
5	PAOZZ	5305-00-903-7298	96906	MS90725-189	SCREW, CAP, HEXAGON H.....	2
6	PAOZZ	5305-00-958-8995	96906	MS90725-188	SCREW, CAP, HEXAGON H.....	6
7	PBOZZ	5310-01-128-5158	97403	13211E7852-1	WASHER, FLAT	2
8	PAOZZ	5305-00-071-2071	96906	MS90728-115	SCREW, CAP, HEXAGON H.....	4
9	PBOZZ	5310-01-128-4123	97403	13211E7852-2	WASHER, FLAT	4
10	PAOZZ	5420-00-496-9609	97403	13211E7819	DECK, EXTRUSION.....	1
11	PBOZZ	5420-00-484-5726	97403	13211E7827	DECK, EXTRUSION.....	5
12	PAOZZ	5310-01-070-2105	96906	MS51967-14	NUT, PLAIN, HEXAGON	76
13	PAOZZ	5310-00-584-5272	96906	MS35338-48	WASHER, LOCK	76
14	PAOZZ	5310-00-167-0823	88044	AN960-816	WASHER, FLAT	136
15	PAOZZ	5305-00-071-2072	96906	MS90728-116	SCREW, CAP, HEXAGON H.....	36
16	PBOZZ	5420-01-065-6134	97403	13211E7829	DECK, EXTRUSION.....	1
17	PFOZZ	2510-01-168-9886	97403	13211E7821	BAR, LIFTING.....	2
18	PAOZZ	5305-00-071-2068	96906	MS90728-112	SCREW, CAP, HEXAGON H.....	36
19	PAOZZ	5420-00-496-9607	97403	13211E7816-1	DECK, EXTRUSION.....	1
20	PBOZZ	5420-01-048-2241	97403	13211E7930	DECK, EXTRUSION.....	1
21	PBOZZ	4730-01-142-8284	97403	13211E7835	CLAMP, PIPE, ANCHOR A.....	3
22	PAOZZ	4730-01-142-8284	96906	MS90725-6	SCREW, CAP, HEXAGON H.....	6
23	PAOZZ	4730-01-159-4852	97403	13222E0986-6	NIPPLE, PIPE (USED ON FEMALE	1
24	PAOZZ	4730-01-159-4848	97403	13222E0986-5	CENTER PANEL ASSY ONLY) NIPPLE, PIPE (USED ON FEMALE	1
25	PAOZZ	4730-00-203-0030	81343	12-12-140239C	CENTER PANEL ASSY ONLY) ELBOW, PIPE (USED ON FEMALE	2
26	PAOZZ	4730-00-182-9086	97403	1321 1E3212	CENTER PANEL ASSY ONLY) COUPLING HALF, QUICK (USED ON.....	1
27	PAOZZ	4730-01-009-0981	81343	12-12-140438S	FEMALE CENTER PANEL ASSY ONLY) TEE, PIPE (USED ON FEMALE	1
28	PAOZZ	4730-01-159-4853	97403	13222E0986-4	CENTER PANEL ASSY ONLY) NIPPLE, PIPE (USED ON FEMALE	1
29	PAOZZ	4730-00-288-9773	81343	12-12-140238C	CENTER PANEL ASSY ONLY) ELBOW, PIPE	3
30	PAOZZ	4730-00-278-3917	97403	12-4-140140C	TUBE, FITTING	2
31	PBOZZ	5340-01-010-0283	97403	13211E7936	CAP, PROTECTIVE, DUST (QTY	V
32	PAOZZ	5305-00-225-3843	96906	MS90728-8	1 MALE, QTY 2 FEMALE) SCREW, CAP, HEXAGON H.....	V
33	PAOZZ	5310-00-823-8804	96906	MS27183-9	(QTY 7 MALE, QTY 9 FEMALE) WASHER, FLAT	6
34	PAOZZ	5310-00-732-0559	96906	MS51968-8	NUT, PLAIN, HEXAGON (USED	2
35	PAOZZ	5310-00-637-9541	96906	MS35338-46	ON MALE CENTER PANEL ASSY ONLY) WASHER, LOCK (USED ON MALE	2
36	PAOZZ	5310-00-167-0821	88044	AN960-616	CENTER PANEL ASSY ONLY) WASHER, FLAT (USED ON MALE	2
37	PFOZZ	4730-01-120-8494	97403	13211E7937	CENTER PANEL ASSY ONLY) FLANGE, PIPE (USED ON MALE	1
38	PAOZZ	5305-00-781-7245	96906	MS35191-323	CENTER PANEL ASSY ONLY) SCREW, MACHINE (USED ON.....	2
39	PBOOD	97403	13211E7814		CENTER PANEL ASSY ONLY) PANEL STRUCTURE, MALE	1

(1) ITEM NO	SECTION II (2) SMR CODE	(3) NSN	(4) CAGEC	TM 5-5420-203-24P C01 (5) PART NUMBER	(6) DESCRIPTION AND USABLE ON CODES (UDC)	(7) QTY
39	PBOOD		97403	1321 IE7826	PANEL STRUCTURE. FEMALE	1
40	PBOZZ	2590-01-134-6541	97403	13211E7833	GUIDE, HOSE ,MALE.....	2
40	PBOZZ	5420-01-121-1220	97403	13211E7823	GUIDE, HOSE, FLEXIBLE , FEMALE.....	2
41	PAOZZ	2590-01-109-5664	97403	13211E3139-2	RETAINER, SPRING, DUS (QTY 1	V
42	PAOZZ	5310-00-582-5965	96906	MS35338-44	WASHER, LOCK (QTY 13 MALE,	V
43	PAOZZ	5310-00-761-6882	96906	MS51967-2	NUT, PLAIN, HEXAGON (QTY 13	V
44	PAOZZ	5310-00-141-1795	88044	AN960-416	WASHER, FLAT (QTY 1 MALE,	V
45	PAOZZ	4730-01-159-4847	97403	13222E0986-7	NIPPLE, PIPE	1
46	PBOZZ	5340-01-129-9885	97403	13211E7848	BRACKET, ANGLE	1
47	PBOZZ	5340-01-129-9884	97403	13211E7815	BRACKET, ANGLE	1
48	PAOZZ	4730-01-126-3763	97403	13222E0986-1	NIPPLE, PIPE (USED ON MALE	1
49	PAOZZ	5340-00-462-4143	97403	13211E3139-1	CENTER PANEL ASSY ONLY) CLIP, SPRING TENSION (USED ON	1
50	PBOZZ	5340-01-129-9883	97403	13211E7839	FEMALE CENTER PANEL ASSY ONLY) BRACKET, ANGLE.....	1

END OF FIGURE

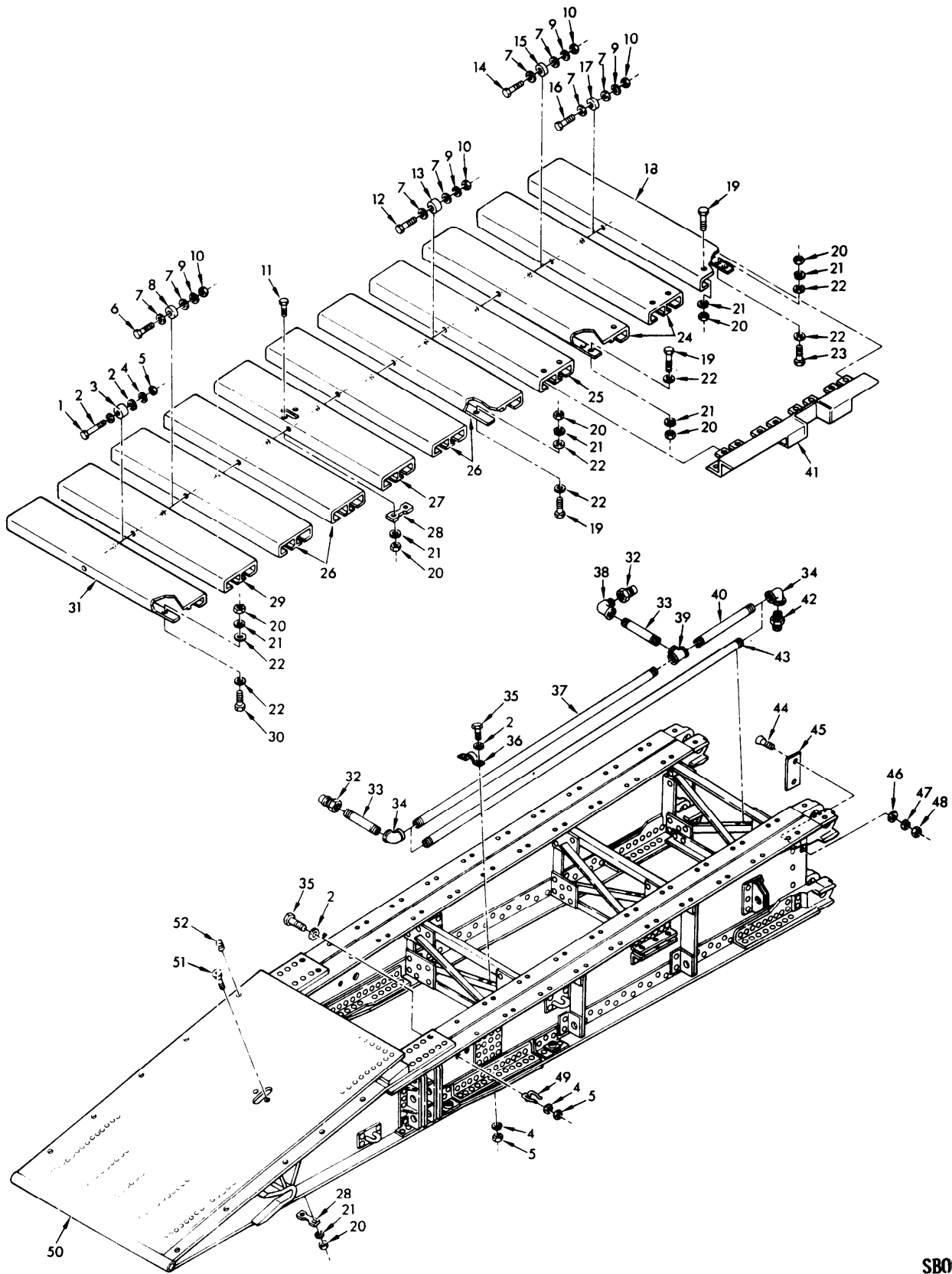
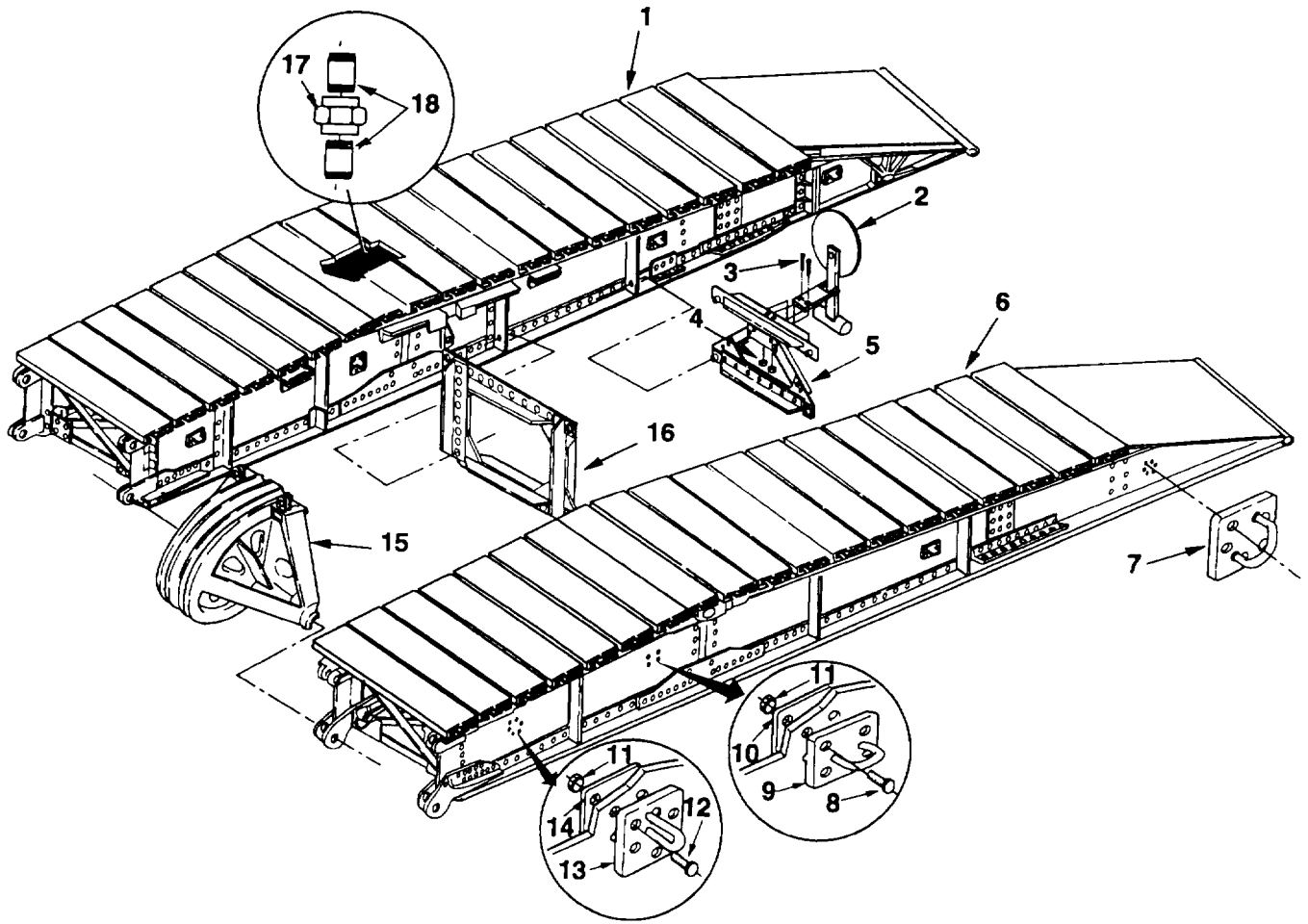

FIGURE 8. END PANEL COMPONENTS (ASSY P/N'S 13211E7843 FEMALE AND 13211E7837 MALE)

SECTION II				TM 5-5420-203-24P, C01		
(1) ITEM NO	(2) SMR CODE	(3) NSN	(4) CAGEC	(5) PART NUMBER	(6) DESCRIPTION AND USABLE ON CODES (UOC)	(7) QTY
1					GROUP 0204 AND 0205	
					FIG. 8 END PANEL COMPONENTS (ASSY P/N'S 13211E7843 FEMALE AND 13211E7837 MALE)	
1	PAOZZ	5305-00-071-2518	96906	MS90728-21	SCREW, CAP, HEXAGON H.....	1
2	PAOZZ	5310-00-141-1795	88044	AN960-416	WASHER, FLAT (QTY 10 MALE QTY 9 FEMALE)	V
3	PBOZZ	5365-01-130-0951	97403	13211E7824	SPACER, SLEEVE	1
4	PAOZZ	5310-00-582-5965	96906	MS35338-44	WASHER, LOCK (QTY 9 MALE QTY 8 FEMALE)	V
5	PAOZZ	5310-00-761-6882	96906	MS51967-2	NUT, PLAIN, HEXAGON (QTY 9 MALE QTY 8 FEMALE)	V
6	PAOZZ	5305-00-947-4354	96906	MS90728-191	SCREW, CAP, HEXAGON H.....	1
7	PAOZZ	5310-00-167-0826	88044	AN960-1216	WASHER, FLAT	18
8	PBOZZ	5365-01-130-0950	97403	13211E7852-5	SPACER, SLEEVE	1
9	PAOZZ	5310-00-584-7888	96906	MS35338-51	WASHER, LOCK	9
10	PAOZZ	5310-00-763-8921	96906	MS51967-23	NUT, PLAIN, HEXAGON	9
11	PAOZZ	5305-00-071-2071	96906	MS90728-115	SCREW, CAP, HEXAGON H.....	2
12	PAOZZ	5305-00-042-9479	96906	MS90725-192	SCREW, CAP, HEXAGON H.....	6
13	PBOZZ	5365-01-128-5311	97403	13211E7852-4	SPACER, SLEEVE	6
14	PAOZZ	5305-00-958-8995	96906	MS90725-188	SCREW, CAP, HEXAGON H.....	1
15	PBOZZ	5310-01-128-5158	97403	13211E7952-1	WASHER, FLAT	1
16	PAOZZ	5305-00-922-7994	96906	MS90728-189	SCREW, CAP, HEXAGON H.....	1
17	PBOZZ	5365-01-128-5311	97403	13211E7852-3	SPACER, SLEEVE	1
18	PBOZZ	5420-01-048-2240	97403	13211E7940	DECK, EXTRUSION ,FEMALE	1
18	PBOZZ	5420-01-109-5665	97403	13211E7859	DECK, BRIDGE, AVLB ,MALE	1
19	PAOZZ	5305-01-071-2068	96906	MS90728-112	SCREW, CAP, HEXAGON H.....	76
20	PAOZZ	5310-01-070-2105	96906	MS51967-14	NUT, PLAIN, HEXAGON	106
21	PAOZZ	5310-00-584-5272	96906	MS35338-48	WASHER, LOCK	106
22	PAOZZ	5310-00-167-0823	88044	AN960-816	WASHER, FLAT	180
23	PAOZZ	5305-00-071-2072	96906	MS90728-116	SCREW, CAP, HEXAGON H.....	20
24	PBOZZ	5420-01-062-5595	97403	13211E7828-2	DECK, EXTRUSION.....	2
25	PBOZZ	5420-01-071-9058	97403	13211E7828-1	DECK, EXTRUSION.....	1
26	PBOZZ	5420-00-484-5726	97403	13211E7827	DECK, EXTRUSION.....	4
27	PBOZZ	5420-01-063-5650	97403	13211E7829	DECK, EXTRUSION ,FEMALE	1
27	PBOZZ	5420-01-065-6134	97403	13211E7816-2	DECK, EXTRUSION ,MALE	1
28	PFOZZ	2510-01-168-9886	97403	13211E7821	BAR, LIFTING.....	2
29	PAOZZ	2510-00-496-9608	97403	13211E7817-2	DECK, EXTRUSION ,FEMALE	1
29	PAOZZ	5420-00-495-6012	97403	13211E7817-1	DECK, EXTRUSION ,MALE	1
30	PAOZZ	5305-00-071-2073	96906	MS90728-117	SCREW, CAP, HEXAGON H.....	6
31	PBOZZ	5420-00-131-4692	97403	13211E7818	DECK, EXTRUSION.....	1
32	PAOZZ	4730-00-182-9086	97403	13211E3212	COUPLING HALF, QUICK (QTY 2 MALE QTY 1 FEMALE)	V
33	PAOZZ	4730-01-159-4847	97403	13222E0986-7	NIPPLE, PIPE (QTY 2 MALE QTY 1 FEMALE)	V
34	PAOZZ	4730-00-288-9773	81343	12-12-140238C	ELBOW, PIPE	2
35	PAOZZ	5305-00-225-3843	96906	MS90728-8	SCREW, CAP, HEXAGON H..... (QTY 8 MALE, QTY 7 FEMALE)	V
36	PBOZZ	4730-01-142-8284	97403	13211E7835	CLAMP, PIPE, ANCHOR A.....	3
37	PAOZZ	4730-01-159-4850	97403	13222E0986-9	NIPPLE, PIPE (USED ON MALE END PANEL ASSY ONLY)	1
38	PAOZZ	4730-00-203-0030	81343	12-12-140239C	ELBOW, PIPE (USED ON MALE END PANEL ASSY ONLY)	1
39	PAOZZ	4730-01-009-0981	81343	12-12-140438S	TEE, PIPE (USED ON MALE END PANEL ASSY ONLY)	1

SECTION II				TM 5-5420-203-24P C01		
(1)	(2)	(3)	(4)	(5)	(6)	(7)
ITEM NO	SMR CODE	NSN	CAGEC	PART NUMBER	DESCRIPTION AND USABLE ON CODES (UDC)	QTY
40	PAOZZ	4730-01-159-4849	97403	13222E0986-11	NIPPLE, PIPE (USED ON MALE END PANEL ASSY ONLY)	1
41	PBOZZ	5420-01-044-8351	97043	13211E7841	RETAINER, DECK END, FEMALE	1
41	PBOZZ	5945-00-131-4684	97403	13211E7847	RETAINER, ELECTRICAL, MALE	1
42	PAOZZ	4730-00-796-0496	96906	MS51500A12S	FITTING. HYDRAULIC T	1
43	PAOZZ	4730-01-159-4851	97403	13222E0986-12	NIPPLE, PIPE (USED ON FEMALE END PANEL ASSY ONLY)	1
44	PAOZZ	5305-00-781-7245	96906	MS35191-323	SCREW. MACHINE	2
45	PFOZZ	4730-01-120-8494	97403	13211E7937	FLANGE. PIPE	1
46	PAOZZ	5310-00-167-0821	88044	AN960-616	WASHER, FLAT	2
47	PAOZZ	5310-00-637-9541	96906	MS35338-46	WASHER, LOCK	2
48	PAOZZ	5310-00-732-0559	96906	MS51968-8	NUT. PLAIN, HEXAGON	2
49	PAOZZ	5430-00-462-4143	97403	13211E3139-1	CLIP, SPRING TENSION (QTY 2 MALE QTY 1 FEMALE)	V
50	PBOOD		97403	13211E7844	PANEL ,FEMALE	1
50	PBOOD		97403	1321 1E7838	PANEL .MALE	1
51	PAOZZ	5305-00-903-3640	96906	MS24667-78	SCREW, CAP, SOCKET HE	2
52	PAOZZ	5340-00-290-4503	96906	MS 122088	INSERT, SCREW THREAD	1

END OF FIGURE



NOTE: ITEM 19 AND 20 NOT SHOWN.

FIGURE 9. MLC 70 QUARTER PANELS AND RELATED COMPONENTS (MALE AND FEMALE)

(1) ITEM NO	SECTION II (2) SMR CODE	(3) NSN	(4) CAGEC	TM 5-5420-203-24P C01 (5) PART NUMBER	(6) DESCRIPTION AND USABLE ON CODES (UDC)	(7) QTY
GROUP 03: FRAME						
FIG. 9 MLC 70 AVLB						
1	PAODD	5420-01-420-1684	97403	13230E4809	MLC 70 MALE (5420-01-420-1684) FOR COMPONENT PARTS SEE ALL 01 AND 02 GROUPS	2
2	PAOZZ	5340-01-416-3913	97403	13230E4896	FLAG, SIGNAL	2
3	PAOZZ	5305-00-225-3845	96906	B1821BH0250100N	SCREW, CAP, HEXAGON, H.....	4
4	PAOZZ	5310-00-929-1807	96906	MS51922-2	NUT, SELF-LOCKING	4
5	PAODD	5420-01-420-1685	97403	13230E4899	BRACE, TRANSVERSE	2
6	PAODD	5420-01-419-9478	97403	13230E4808	MLC 70 FEMALE . (5420-01-419-9475)..... FOR COMPONENT PARTS SEE ALL 01 AND 02 GROUPS	2
7	PAOZZ	5340-01-424-5907	97403	13230E6453	BRACKET, LIFTING, RIGHT	6
8	PAOZZ	5305-00-916-2345	96906	B1821BH075F200N	SCREW, CAP, HEXAGON	80
9	PAOZZ	5420-01-419-9485	97403	13230E4893	BRACKET, TIEDOWN	20
10	PAOZZ	5420-01-419-9483	97403	13230E4894	PLATE, TIEDOWN	20
11	PAOZZ	5310-00-982-6810	96906	MS21044N12	NUT, SELF-LOCKING, HE	152
12	PAOZZ	5305-00-948-0803	96906	B1821BH075F300N	SCREW, CAP, HEXAGON	72
13	PAOZZ	5340-01-424-5908	97403	13230E6454	BRACKET, LIFTING, LEFT	6
14	PAOZZ	5340-01-424-5909	97403	13230E6455	PLATE, LIFTING, AVLB.....	12
15	PAOOF	2590-01-431-4438	97403	12463645	QUADRANT ASSY	1
16	PAODD	5420-01-419-9481	97403	13230E6447	BRACE, TRANSVERSE	4
17	PAOZZ	4730-01-023-7729	59646	MSS SP-03	PIPE UNION, 3/4 NPS, CL3000	4
18	PAOZZ	4730-01-159-4849	97403	13222E0986-11	NIPPLE, PIPE	V
19	PAOZZ	5305-00-068-0510	96906	B1821BH038C100N	SCREW, CAP, HEXAGON (NOT SHOWN)	16
20	PAOZZ	5365-01-393-1243	97403	13230E4810	PLATE, RETAINING (NOT SHOWN)	
END OF FIGURE						

SECTION IV

TM 5-5420-203-24P C01
 CROSS- REFERENCE-INDEXES
 NATIONAL STOCK NUMBER INDEX

STOCK NUMBER	FIG.	ITEM	STOCK NUMBER	FIG.	ITEM
5305-00-042-9479	8	12	4730-00-278-3917	1	9
5305-00-050-4212	5	15	4730-00-288-9773	8	34
5420-00-059-9809	5	8	5340-00-290-4503	8	52
5420-00-060-7030	4	9	5315-00-298-1481	6	5
5420-00-060-7031	3	8.1	5420-00-449-7172	2	16
	6	20.1	5330-00-450-6605	2	8
5420-00-060-7032	3	4.1	5340-00-462-4143	7	49
	4	14.1		8	49
	4	3.1	5420-00-484-5726	7	11
	5	4.1		8	26
	5	7.1	5420-00-495-6012	8	29
5420-00-061-2873	4	25	5420-00-496-9607	7	19
5305-00-068-0502	7	22	2510-00-496-9608	8	29
5305-00-068-0510	9	19	5420-00-496-9609	7	10
5305-00-071-2068	7	18	1650-00-516-8336	2	2
	8	19	5420-00-542-3115	4	2
5305-00-071-2071	7	8	5420-00-542-3116	4	15
	8	11	5420-00-542-3117	5	6
5305-00-071-2072	7	15	2510-00-542-3118	5	3
	8	23	5420-00-542-3122	5	22
5305-00-071-2073	8	30	5420-00-542-3123	4	16
5305-00-071-2518	8	1	5420-00-542-3124	5	19
5945-00-131-4684	8	41	5420-00-542-3125	5	21
5420-00-131-4692	8	31	5306-00-542-3126	3	2
5310-00-141-1795	7	44		4	23
	8	2		5	20
5310-00-167-0821	7	36	5420-00-542-3127	5	23
	8	46	5420-00-542-3128	5	18
5310-00-167-0823	7	14	5420-00-542-3129	5	14
	8	22	5420-00-542-3130	4	1
5310-00-167-0826	4	19	5420-00-542-3131	4	26
	5	17	5420-00-542-3132	4	7
	7	3	5420-00-542-3133	4	8
	8	7		4	24
5420-00-182-8639	1	13	5420-00-542-3134	4	6
4730-00-182-9086	1	5	5420-00-542-3135	4	5
	6	10	5420-00-542-3136	4	3
	7	26		5	7
	8	32	5420-00-542-3137	3	3
5420-00-186-3405	2	19	5420-00-542-3138	3	7
4730-00-202-8469	1	2	5420-00-542-3139	3	9
	6	2	5420-00-542-3140	3	6
	6	12	5420-00-542-3141	3	5
4730-00-203-0030	1	8	5420-00-542-3143	3	4
	7	25	5420-00-542-3144	6	20
	8	38	5420-00-542-3145	3	8
5305-00-225-3843	7	32		5	4
	8	35	5420-00-542-3146	3	11
	9	3	5420-00-542-3147	3	12
5305-00-226-7767	1	14	5420-00-542-3148	3	10
5420-00-235-4684	2	9	5420-00-542-3149	6	19
2590-00-240-8935	4	4	5420-00-542-3151	3	1
4820-00-249-4203	1	10	5420-00-542-3152	6	6
4730-00-257-0236	1	4	5420-00-542-3153	6	4
4730-00-257-0236	6	14	5420-00-542-3154	5	5
4730-00-277-9457	1	6	5420-00-542-3156	1	20

SECTION IV

 TM 5-5420-203-24P C01
 CROSS- REFERENCE-INDEXES
 NATIONAL STOCK NUMBER INDEX

STOCK NUMBER	FIG.	ITEM	STOCK NUMBER	FIG.	ITEM
5420-00-542-3157	1	11	5305-00-947-4353	1	22
5420-00-542-3192	1	21	5305-00-947-4354	8	6
5330-00-579-9675	2	7	5305-00-947-4361	4	22
5310-00-582-5965	7	42		5	16
	8	4	5305-00-948-0803	9	12
5310-00-584-5272	1	15	5305-00-958-8995	7	6
	6	17		8	14
	7	13	5310-00-982-6810	9	11
	8	21	5310-00-983-8485	5	10
5310-00-584-7888	1	18	4720-00-986 6932	6	11
	4	20	5305-00-993-1849	2	13
	5	2	4730 01-009-0981	1	7
	7	2		7	27
	8	9		8	39
5315-00-597-7399	1	12	5340 01-010-0283	7	31
2805-00-606-4396	2	20	5365-01-011-5038	5	12
2590-00-606-4474	2	4	5315-01-016-6654	6	7
5330-00-618-4602	2	14	4730-01-017-0264	6	3
5310-00-637-9541	8	47	4730-01-023-7729	9	17
	7	35	5310-01-032-2318	5	9
5420-00-682-4517	4	14	5305-11-038-8424	2	11
5365-00-689-3127	2	3	5420-01-044-8351	8	41
5305-00-724-7875	2	22	5420-01-045-3562	2	5
5330-00-729-6632	2	17	5420-01-048-2240	8	18
4720-00-731-5332	4	13	5420-01-048-2241	7	20
4720-00-731-5333	4	17	5420-01-062-5595	8	24
5305-00-732-0511	6	15	5420-01-063-5650	8	27
5310-00-732-0559	7	34	5420-01-065-6134	7	16
	8	48		8	27
4720-00-732-3418	1	1	5310-01-070-2105	6	18
5310-00-761-6882	7	43		7	12
	8	5		8	20
5310-00-763-8921	1	19	5420-01-071-9058	8	25
	4	21	5420-01-104-9108	1	16
	5	1	5340-01-109-5663	4	10
	7	1	2590-01-109-5664	7	41
	8	10	5420-01-109-5665	8	18
5305-00-781-7245	7	38	5420-01-120-3020	2	21
	8	44	4730-01-120-8494	7	37
4730-00-796-0496	8	42		8	45
5310-00-809-8533	4	12	5420-01-121-1220	7	40
5310-00-809-5998	6	16	5420-01-121-1549	2	1
5420-00-816-5649	1	3	5420-01-121-1608	2	23
	6	13	5330-01-121-2778	2	15
5310-00-823-8804	7	33	4730-01-126-3763	7	48
5315-00-839-5821	6	8	5310-01-128-4123	7	9
5340-00-872-7696	2	10	5310-01-128-5158	7	7
5330-00-883-0233	2	6		8	15
5305-00-903-3640	8	51	5330-01-128-5202	2	18
5305-00-903-7298	5	13	5365-01-128-5311	7	4
5305-00-903-7298	7	5		8	17
5305-00-904-4004	2	12	5340-01-129-9883	7	50
5305-00-916-2345	9	8	5340-01-129-9884	7	47
5305-00-922-7994	4	18	5340-01-129-9885	7	46
	8	16	5365 01-130-0949	8	13
5310-00-929-1807	9	4	5365-01-130-0950	8	8

SECTION IV

TM 5-5420-203-24P C01
 CROSS- REFERENCE-INDEXES
 NATIONAL STOCK NUMBER INDEX

STOCK NUMBER	FIG.	ITEM	STOCK NUMBER	FIG.	ITEM
5365-01-130-0951	8	3			
2590-01-134-6541	7	40			
5306-01-136-1186	5	11			
4730-01-142-8284	7	21			
	8	36			
5340-01-145-1968	1	17			
4730-01-159-4847	7	45			
	8	33			
4730-01-159-4848	7	24			
4730-01-159-4849	8	40			
	9	18			
4730-01-159-4850	8	37			
4730-01-159-4851	8	43			
4730-01-159-4852	7	23			
4730-01-159-4853	7	28			
2510-01-168-9886	7	17			
	8	28			
4730-01-169-2452	6	9			
4730-01-281-7903	6	2			
5365-01-393-1243	9	20			
5340-01-416-3913	9	2			
5420-01-419-9478	9	6			
5420-01-419-9481	9	16			
5420-01-419-9483	9	10			
5420-01-419-9485	9	9			
5420-01-420-1684	9	1			
5420-01-420-1685	9	5			
5340-01-424-5907	9	7			
5340-01-424-5908	9	13			
5340-01-424-5909	9	14			
2590-01-431-4438	9	15			

SECTION IV

 TM 5-5420-203-24P C01
 CROSS-REFERENCE INDEXES
 PART NUMBER INDEX

FSCM	PART NUMBER	STOCK NUMBER	FIG.	ITEM
59646	MSS SP-03	4730-01-023-7729	9	17
88044	AN960-1216	5310-00-167-0826	4	19
			5	17
			7	3
			8	7
88044	AN960-416	5310-00-141-1795	7	44
			8	2
88044	AN960-616	5310-00-167-0821	7	36
			8	46
88044	AN960-816	5310-00-167-0823	7	14
			8	22
98441	A 1150-1	4720-00-731-5333	4	17
98441	A 1150-4	4720-00-731-5332	4	13
96906	B1821BH025CI00N	5305-00-225-3843	9	3
96906	B1821BH038C100N	5305-00-068-0510	9	19
80204	B1821BH075F200N	5305-00-916-2345	9	8
96906	B1821BH075F300N	5305-00-948-0803	9	12
81349	MILR52243	5420-00-060-7032	3	4.1
		5420-00-060-7031	3	8.1
		5420-00-060-7032	4	3.1
		5420-00-060-7032	4	14.1
		5420-00-060-7031	5	4.1
		5420-00-060-7032	5	7.1
		5420-00-060-7031	6	20.1
96906	MS122088	5340-00-290-4503	8	52
96906	MS21044N12	5310-00-982-6810	9	11
96906	MS24665-351	5315-00-839-5821	6	8
96906	MS24665-357	5315-00-298-1481	6	5
96906	MS24665-631	5315-00-597-7399	1	12
96906	MS24667-78	5305-00-903-3640	8	51
96906	MS27183-18	5310-00-809-5998	6	16
96906	MS27183-23	5310-00-809-8533	4	12
96906	MS27183-30	5310-00-983-8485	5	10
96906	MS27183-9	5310-00-823-8804	7	33
96906	MS27595-244	5330-01-128-5202	2	18
96906	MS27595-441	5330-00-883-0233	2	6
96906	MS27595-451	5330-01-121-2778	2	15
96906	MS28775-244	5330-00-729-6632	2	17
96906	MS28775-441	5330-00-579-9675	2	7
96906	MS28775-451	5330-00-618-4602	2	14
96906	MS28776M2-41	1650-00-516-8336	2	2
96906	MS35191-323	5305-00-781-7245	7	38
			8	44
96906	MS35207-259	5305-00-993-1849	2	13
96906	MS35338-44	5310-00-582-5965	7	42
			8	4
96906	MS35338-46	5310-00-637-9541	7	35
			8	47
96906	MS35338-48	5310-00-584-5272	1	15
			6	17
			7	13
			8	21

SECTION IV

TM 5-5420-203-24P C01
CROSS-REFERENCE

FSCM	PART NUMBER	PART NUMBER INDEX STOCK NUMBER	FIG.	ITEM
96906	MS35338-51	5310-00-584-7888	1	18
			4	20
			5	2
			7	2
96906	MS51500A12	4730-00-202-8469	8	9
			1	2
			6	2
96906	MS51500A12S	4730-00-796-0496	6	12
			8	42
96906	MS51922-2	5310-00-929-1807	9	4
96906	MS51943-53	5310-01-032-2318	5	9
96906	MS51966-8	5305-00-724-7875	2	22
96906	MS51967-14	5310-01-070-2105	6	18
96906	MS51967-2	5310-00-761-6882	7	12
			8	20
			7	43
96906	MS51967-23	5310-00-763-8921	8	5
			1	19
96906	MS51968-8	5310-00-732-0559	4	21
			5	1
			7	1
			8	0
			7	34
			8	48
96906	MS90725-186	5305-00-050-4212	5	15
96906	MS90725-188	5305-00-958-8995	7	6
96906	MS90725-189	5305-00-903-7298	8	14
			5	13
			7	5
96906	MS90725-192	5305-00-042-9479	8	12
96906	MS90725-6	5305-00-068-0502	7	22
96906	MS90726-109	5305-00-226-7767	1	14
96906	MS90727-209	5305-00-904-4004	2	12
96906	MS90728-110	5305-00-732-0511	6	15
96906	MS90728-112	5305-00-071-2068	7	18
96906	MS90728-115	5305-00-071-2071	8	19
			7	8
96906	MS90728-116	5305-00-071-2072	8	11
			7	15
96906	MS90728-117	5305-00-071-2073	8	23
			8	30
96906	MS90728-189	5305-00-922-7994	4	18
96906	MS90728-190	5305-00-947-4353	8	16
			1	22
96906	MS90728-191	5305-00-947-4354	8	6
96906	MS90728-198	5305-00-947-4361	4	22
96906	MS90728-21	5305-00-071-2518	5	16
			8	1
96906	MS90728-8	5305-00-225-3843	7	32
81348	WWN351TYPEB	4730-00-277-9457	8	35
			1	6

SECTION IV

TM 5-5420-203-24P C01
CROSS-REFERENCE INDEXES

FSCM	PART NUMBER	PART NUMBER INDEX STOCK NUMBER	FIG.	ITEM
81343	12-4-140140C	4730-00-278-3917	1	9
81343	12-12-140238C	4730-00-288-9773	7	29
			8	34
81343	12-12-140438S	4730-01-009-0981	1	7
			7	27
			8	39
81343	12-12-140239C	4730-00-203-0030	1	8
			7	25
			8	38
19207	12463568	TBD	10	1
97403	12463645	2590-01-431-4438	9	15
97403	13207E9894	5420-00-060-7030	4	9
97403	13211E3121-4	2805-00-606-4396	2	20
97403	13211E3139-1	5340-00-462-4143	7	49
			8	49
97403	13211E3139-2	2590-01-109-5664	7	41
97403	13211E3142-4	5330-00-450-6605	2	8
97403	13211E3144-4	2590-00-606-4474	2	4
97403	13211E3147	5340-00-872-7696	2	10
97403	13211E3212	4730-00-182-9086	1	5
			6	10
			7	26
			8	32
97403	13211E3213	4730-00-257-0236	1	4
			6	14
97403	13211E7813	5420-00-542-3116	4	15
97403	13211E7814		7	39
97403	13211E7815	5340-01-129-9884	7	47
97403	13211E7816-1	5420-00-496-9607	7	19
97403	13211E7816-2	5420-01-063-5650	8	27
97403	13211E7817-1	5420-00-495-6012	8	29
97403	13211E7817-2	2510-00-496-9608	8	29
97403	13211E7818	5420-00-131-4692	8	31
97403	13211E7819	5420-00-496-9609	7	10
97403	13211E7820	5420-00-542-3136	4	3
			5	7
97403	13211E7821	2510-01-168-9886	7	17
			8	28
97403	13211E7823	5420-01-121-1220	7	40
97403	13211E7824	5365-01-130-0951	8	3
97403	13211E7825	5420-00-542-3115	4	2
97403	13211E7825-41		7	30
97403	13211E7826		7	39
97403	13211E7827	5420-00-484-5726	7	11
			8	26
97403	13211E7828-1	5420-01-071-9058	8	25
97403	13211E7828-2	5420-01-062-5595	8	24
97403	13211E7829	5420-01-065-6134	7	16
			8	27
97403	13211E7831	5420-00-816-5649	1	3
			6	13
97403	13211E7833	2590-01-134-6541	7	40

FSCM	PART NUMBER	PART NUMBER INDEX STOCK NUMBER	FIG.	ITEM
97403	13211E7835	4730-01-142-8284	7	21
			8	36
97403	13211E7836	5420-00-542-3128	5	18
97403	13211E7837	5420-00-542-3117	5	6
			8	50
97403	13211E7839	5340-01-129-9883	7	50
97403	13211E7841	5420-01-044-8351	8	41
97403	13211E7842	4820-00-249-4203	1	10
97403	13211E7843	2510-00-542-3118	5	3
97403	13211E7844		8	50
97403	13211E7846	5420-00-542-3144	6	20
97403	13211E7847	5945-00-131-4684	8	41
97403	13211E7848	5340-01-129-9885	7	46
97403	13211E7849	4730-01-281-7903	6	1
97403	13211E7850	5420-00-542-3149	6	19
97403	13211E7851	5420-00-542-3151	3	1
97403	13211E7852-1	5310-01-128-5158	7	7
			8	15
97403	13211E7852-2	5310-01-128-4123	7	9
97403	13211E7852-3	5365-01-128-5311	7	4
			8	17
97403	13211E7852-4	5365-01-130-0949	8	13
97403	13211E7852-5	5365-01-130-0950	8	8
97403	13211E7854	5420-00-542-3153	6	4
97403	13211E7855	5420-00-542-3152	6	6
97403	13211E7855-3	5315-01-016-6654	6	7
97403	13211E7856	5420-00-542-3129	5	14
97403	13211E7857	5420-00-542-3132	4	7
97403	13211E7858	5420-00-542-3130	4	1
97403	13211E7859	5420-01-109-5665	8	18
97403	13211E7860	2590-00-240-8935	4	4
97403	13211 E7860-5		4	11
97403	13211E7861	5420-00-542-3135	4	5
97403	13211E7862	5420-00-542-3133	4	8
			4	24
97403	13211E7863	5420-00-542-3134	4	6
97403	13211E7867	5420-00-186-3405	2	19
97403	13211E7868	5365-00-689-3127	2	3
97403	13211E7871	5420-01-121-1549	2	1
97403	13211E7873	5420-00-542-3157	1	11
97403	13211E7874	5420-00-542-3156	1	20
97403	13211E7875	5420-01-121-1608	2	23
97403	13211E7876	5420-00-235-4684	2	9
97403	13211E7879	5420-00-542-3154	5	5
97403	13211E7880	5420-01-104-9108	1	16
97403	13211E7880-8	5305-01-038-8424	2	11
97403	13211E7881	5420-00-542-3147	3	12
97403	13211.7882	5420-00-542-3139	3	9
97403	13211E7883	5420-00-542-3138	3	7
97403	13211E7884	5420-00-542-3148	3	10
97403	13211E7885	5420-00-542-3146	3	11

SECTION IV

TM 5-5420-203-24P C01
CROSS-REFERENCE INDEXES

FSCM	PART NUMBER	PART NUMBER INDEX STOCK NUMBER	FIG.	ITEM
97403	1321117886	5420-00-542-3122	5	22
97403	132111 7887	5420-00-542-3125	5	21
97403	13211E7888	5420-00-542-3124	5	19
97403	132111-7890	5420-00-542-3137	3	3
97403	1321 117891	5420-00-682-4517	4	14
97403	132111E7892	5420-00-182-8639	1	13
97403	132111t7893	5420-00-542-3141	3	5
97403	13211E7897	5420-00-542-3123	4	16
97403	13211E7898	5306-00-542-3126	3	2
			4	23
			5	20
97403	13211E7899	5420-00-542-3127	5	23
97403	13211E7903	5420-00-542-3140	3	6
97403	13211E7904-2	4720-00-986-6932	6	11
97403	13211E7904-3	4720-00-732-3418	1	1
97403	13211E7905-14		1	9
97403	13211E7913	5420-00-542-3131	4	26
97403	13211E7922	5306-01-136-1186	5	11
97403	13211E7923	5365-01-011-5038	5	12
97403	13211E7926	5420-00-542-3145	3	8
			5	4
97403	13211E7929	5420-00-059-9809	5	8
97403	13211E7930	5420-01-048-2241	7	20
97403	13211E7931	5420-00-542-3143	3	4
97403	1321117932	4730-01-017-0264	6	3
97403	13211E7934	5340-01-109-5663	4	10
97403	13211E7935	5420-00-542-3192	1	21
97403	13211E7936	5340-01-010-0283	7	30
			7	31
97403	13211E7937	4730-01-120-8494	7	37
			8	45
97403	13211E7939	5340-01-145-1968	1	17
97403	13211E7940	5420-01-048-2240	8	18
97403	13214E0023-4	5420-00-449-7172	2	16
97403	13214E00'5-'	5420-01-120-30'0	2	21
97403	13214E0033-1	5420-01-045-3562	2	5
97403	13222E0986-1	4730-01-126-3763	7	48
97403	13"222E0986-11	4730-01-159-4849	8	40
97403	13222I0986-12	4730-01-159-4851	8	43
97403	13222E0986-3	4730-01-169-2452	6	9
97403	13222E0986-4	4730-01-159-4853	7	28
97403	13222E0986-5	4730-01-159-4848	7	24
97403	13222E0986-6	4730-01-159-4852	7	23
97403	13222E0986-7	4730-01-159-4847	7	45
			8	33
97403	13222E0986-9	4730-01-159-4850	8	37
97403	13222E0986-11	4730-01-159-4849	9	18
97403	13230E4808	5420-01-419-9478	9	6
97403	13230E4809	5420-01-420-1684	9	1
97403	13230E4810	5365-01-393-1243	9	20
97403	13230E4893	5420-01-419-9485	9	9

CROSS-REFERENCE INDEXES

PART NUMBER INDEX

FSCM	PART NUMBER	STOCK NUMBER	FIG.	ITEM
97403	13230E4894	5420-01-419-9483	9	10
97403	13230E4896	5340-01-416-3913	9	2
97403	13230E4899	5420-01-420-1685	9	5
97403	13230E6447	5420-01-419-9481	9	16
97403	13230E6453	5340-01-424-5907	9	7
97403	13230E6454	5340-01-424-5908	9	13
97403	13230E6455	5340-01-424-5909	9	14

CROSS-REFERENCE INDEXES
FIGURE AND ITEM NUMBER INDEX
STOCK NUMBER

FIG.	ITEM	STOCK NUMBER	FSCM	PART NUMBER
1	1	4720-00-732-3418	97403	13211E7904-3
1	2	4730-00-202-8469	96906	MS51500A12
1	3	5420-00-816-5649	97403	13211E7831
1	4	4730-00-257-0236	97403	13211E3213
1	5	4730-00-182-9086	97403	13211 E3212
1	6	4730-00-277-9457	81348	WW351TYPEB
1	7	4730-01-009-0981	81343	12-12-140438S
1	8	4730-00-203-0030	81343	12-12-140239C
1	9	4730-00-278-3917	81343	12-4-140140C
1	10	4820-00-249-4203	97403	13211E7842
1	11	5420-00-542-3157	97403	13211E7873
1	12	5315-00-597-7399	96906	MS24665-631
1	13	5420-00-182-8639	97403	13211E7892
1	14	5305-00-226-7767	96906	MS90726-109
1	15	5310-00-584-5272	96906	MS35338-48
1	16	5420-01-104-9108	97403	13211E7880
1	17	5340-01-145-1968	97403	13211E7939
1	18	5310-00-584-7888	96906	MS35338-51
1	19	5310-00-763-8921	96906	MS51967-23
1	20	5420-00-542-3156	97403	13211E7874
1	21	5420-00-542-3192	97403	13211E7935
1	22	5305-00-947-4353	96906	MS90728-190
2	1	5420-01-121-1549	97403	13211E7871
2	2	1650-00-516-8336	96906	MS28776M2-41
2	3	5365-00-689-3127	97403	13211E7868
2	4	2590-00-606-4474	97403	13211E3144-4
2	5	5420-01-045-3562	97403	13214E0033-1
2	6	5330-00-883-0233	96906	MS27595441
2	7	5330-00-579-9675	96906	MS28775-441
2	8	5330-00-450-6605	97403	13211E3142-4
2	9	5420-00-235-4684	97403	13211E7876
2	10	5340-00-872-7696	97403	13211E3147
2	11	5305-01-038-8424	97403	13211 IE7880-8
2	12	5305-00-904-4004	96906	MS90727-209
2	13	5305-00-993-1849	96906	MS35207-259
2	14	5330-00-618-4602	969d6	MS28775451
2	15	5330-01-121-2778	96906	MS27595451
2	16	5420-00-449-7172	97403	13214E0023-4
2	17	5330-00-729-6632	96906	MS28775-244
2	18	5330-01-128-5202	96906	MS27595-244
2	19	5420-00-186-3405	97403	13211E7867
2	20	2805-00-606-4396	97403	13211E3121-4
2	21	5420-01-120-3020	97403	13214E0025-2
2	22	5305-00-724-7875	96906	MS51966-8
2	23	5420-01-121-1608	97403	13211E7875
3	1	5420-00-542-3151	97403	13211 E7851
3	2	5306-00-542-3126	97403	13211E7898
3	3	5420-00-542-3137	97403	13211E7890
3	4	5420-00-542-3143	97403	13211E7931
3	4.1	5420-00-060-7032	81349	MILR52243
3	5	5420-00-542-3141	97403	13211E7893
3	6	5420-00-542-3140	97403	13211E7903
3	7	5420-00-542-3138	97403	13211E7883
3	8	5420-00-542-3145	97403	13211E7926
3	8.1	5420-00-060-7031	81349	MILR52243
3	9	5420-00-542-3139	97403	13211E7882

CROSS-REFERENCE INDEXES
FIGURE AND ITEM NUMBER INDEX
STOCK NUMBER

FIG.	ITEM	STOCK NUMBER	FSCM	PART NUMBER
3	10	5420-00-542-3148	97403	13211E7884
3	11	5420-00-542-3146	97403	13211E7885
3	12	5420-00-542-3147	97403	13211E7881
4	1	5420-00-542-3130	97403	13211E7858
4	2	5420-00-542-3115	97403	13211E7825
4	3	5420-00-542-3136	97403	13211E7820
4	3.1	5420-00-060-7032	81349	MILR52243
4	4	2590-00-240-8935	97403	13211E7860
4	5	5420-00-542-3135	97403	13211E7861
4	6	5420-00-542-3134	97403	13211E7863
4	7	5420-00-542-3132	97403	13211E7857
4	8	5420-00-542-3133	97403	13211E7862
4	9	5420-00-060-7030	97403	13207E9894
4	10	5340-01-109-5663	97403	13211E7934
4	11		97403	13211E7860-5
4	12	5310-00-809-8533	96906	MS27183-23
4	13	4720-00-731-5332	98441	A1150-4
4	14	5420-00-682-4517	97403	13211E7891
4	14.1	5420-00-060-7032	81349	MILR52243
4	15	5420-00-542-3116	97403	13211E7813
4	16	5420-00-542-3123	97403	13211E7897
4	17	4720-00-731-5333	98441	A1150-1
4	18	5305-00-922-7994	96906	MS90728-189
4	19	5310-00-167-0826	88044	AN960-1216
4	20	5310-00-584-7888	96906	MS35338-51
4	21	5310-00-763-8921	96906	MS51967-23
4	22	5305-00-947-4361	96906	MS90728-198
4	23	5306-00-542-3126	97403	13211E7898
4	24	5420-00-542-3133	97403	13211E7862
4	25	5420-00-061-2873	81349	MILR52243
4	26	5420-00-542-3131	97403	13211E7913
5	1	5310-00-763-8921	96906	MS51967-23
5	2	5310-00-584-7888	96906	M35338-51
5	3	2510-00-542-3118	97403	13211E7843
5	4	5420-00-542-3145	97403	13211E7926
5	4.1	5420-00-060-7031	81349	MILR52243
5	5	5420-00-542-3154	97403	13211E7879
5	6	5420-00-542-3117	97403	13211E7837
5	7	5420-00-542-3136	97403	13211E7820
5	7.1	5420-00-060-7032	81349	MILR52243
5	8	5420-00-059-9809	97403	13211E7929
5	9	5310-01-032-2318	96906	MS51943-53
5	10	5310-00-983-8485	96906	MS27183-30
5	11	5306-01-136-1186	97403	13211E7922
5	12	5365-01-011-5038	97403	13211E7923
5	13	5305-00-903-7298	96906	MS90725-189
5	14	5420-00-542-3129	97403	13211E7856
5	15	5305-00-050-4212	96906	MS90725-186
5	16	5305-00-947-4361	96906	MS90728-198
5	17	5310-00-167-0826	88044	AN960-1216
5	18	5420-00-542-3128	97403	13211E7836
5	19	5420-00-542-3124	97403	13211E7888
5	20	5306-00-542-3126	97403	13211E7898
5	21	5420-00-542-3125	97403	13211E7887
5	22	5420-00-542-3122	97403	13211E7886
5	23	5420-00-542-3127	97403	13211E7899

CROSS-REFERENCE INDEXES
FIGURE AND ITEM NUMBER INDEX
STOCK NUMBER

FIG.	ITEM	STOCK NUMBER	FSCM	PART NUMBER
6	1	4730-01-281-7903	97403	13211E7849
6	2	4730-00-202-8469	96906	MS51500A12
6	3	4730-01-017-0264	97403	13211E7932
6	4	5420-00-542-3153	97403	13211E7854
6	5	5315-00-298-1481	97906	MS24665-357
6	6	5420-00-542-3152	97403	13211E7855
6	7	5315-01-016-6654	97403	13211E7855-3
6	8	5315-00-839-5821	96906	MS24665-351
6	9	4730-01-169-2452	97403	13222E0986-3
6	10	4730-00-182-9086	97403	13211E3212
6	11	4720-00-986-6932	97403	13211 E7904-2
6	12	4730-00-202-8469	96906	MS51500A12
6	13	5420-00-816-5649	97403	13211E7831
6	14	4730-00-257-0236	97403	13211E3213
6	15	5305-00-732-0511	96906	MS90728-110
6	16	5310-00-809-5998	96906	MS27183-18
6	17	5310-00-584-5272	96906	MS35338-48
6	18	5310-01-070-2105	96906	MS51967-14
6	19	5420-00-542-3149	97403	13211E7850
6	20	5420-00-542-3144	97403	13211E7846
6	20.1	5420-00-060-7031	81349	MILR52243
7	1	5310-00-763-8921	96906	MS51967-23
7	2	5310-00-584-7888	96906	MS35338-51
7	3	5310-00-167-0826	88044	AN960-1216
7	4	5365-01-128-5311	97403	13211 IE7852-3
7	5	5305-00-903-7298	97906	MS90725-189
7	6	5305-00-958-8995	96906	MS90725-188
7	7	5310-01-128-5158	97403	13211E7852-1
7	8	5305-00-071-2071	97906	MS90728-115
7	9	5310-01-128-4123	97403	13211E7852-2
7	10	5420-00-496-9609	97403	13211E7819
7	11	5420-00-484-5726	97403	13211E7827
7	12	5310-01-070-2105	96906	MS51967-14
7	13	5310-00-584-5272	96906	MS3533848
7	14	5310-00-167-0823	88044	AN960-816
7	15	5305-00-071-2072	96906	MS90728-116
7	16	5420-01-065-6134	97403	13211E7829
7	17	2510-01-168-9886	97403	13211E7821
7	18	5305-00-071-2068	96906	MS90728-112
7	19	5420-00-496-9607	97403	13211 E7816-1
7	20	5420-01-048-2241	97403	13211E7930
7	21	4730-01-142-8284	97403	13211E7835
7	22	5305-00-068-0502	96906	MS90725-6
7	23	4730-01-159-4852	97403	13222E0986-6
7	24	4730-01-1594848	97403	13222E0986-5
7	25	4730-00-203-0030	81343	12-12-140239C
7	26	4730-00-182-9086	97403	13211E3212
7	27	4730-01-009-0981	81343	12-12-140438S
7	28	4730-01-1594853	97403	13222E0986-4
7	29	4730-00-288-9773	81343	12-12-140238
7	30		97403	1321 IE7825-41
7	31	5340-01-010-0283	97403	13211E7936
7	32	5305-00-255-3843	96906	MS90728-8
7	33	5310-00-823-8804	96906	MS27183-9
7	34	5310-00-732-0559	96906	MS51968-8
7	35	531000-637-9541	96906	MS35338-46

CROSS-REFERENCE INDEXES
FIGURE AND ITEM NUMBER INDEX
STOCK NUMBER

FIG.	ITEM	STOCK NUMBER	FSCM	PART NUMBER
7	36	5310-00-167-0821	88044	AN960-616
7	37	4130-01-120-8494	97403	13211E7937
7	38	5305-00-781-7245	96906	MS35191-323
7	39		97403	1321 IE7814
7	39		97403	13211E7826
7	40	2590-01-134-6541	97403	13211E7833
7	40	5420-01-121-1220	97403	13211IE7823
7	41	2590-01-109-5664	97403	13211E3139-2
7	42	5310-00-582-5965	97906	MS35338-44
7	43	5310-00-761-6882	96906	MS51967-2
7	44	5310-00-141-1795	88044	AN960-416
7	45	4730-01-159-4847	97403	13222E0986-7
7	46	5340-01-129-9885	97403	13211E7848
7	47	5340-01-129-9884	97403	13211E7815
7	48	4730-01-126-3763	97403	13222E0986-1
7	49	5340-00-462-4143	97403	1321 IE3139-1
7	50	5340-01-129-9883	97403	13211E7839
8	1	5305-00-071-2518	96906	MS90728-21
8	2	5310-00-141-1795	88044	AN960-416
8	3	5365-01-130-0951	97403	13211E7824
8	4	5310-00-582-5965	96906	MS35338-44
8	5	5310-00-761-6882	96906	MS51967-2
8	6	5305-00-947-4354	96906	MS90728-191
8	7	5310-00-167-0826	88044	AN960-1216
8	8	5365-01-130-0950	97403	13211 IE7852-5
8	9	5310-00-584-7888	96906	MS35338-51
8	10	5310-00-763-8921	96906	MS51967-23
8	11	5305-00-071-2071	96906	MS90728-115
8	12	5305-00-042-9479	96906	MS90725-192
8	13	5365-01-130-0949	97403	13211 E7852-4
8	14	5305-00-958-8995	96906	MS90725-188
8	15	5310-01-128-5158	97403	13211E7852-1
8	16	5305-00-922-7994	96906	MS90728-189
8	17	5365-01-128-5311	97403	13211E7852-3
8	18	5420-01-048-2240	97403	13211E7940
8	18	5420-01-109-5665	97403	13211E7859
8	19	5305-01-071-2068	96906	MS90728-112
8	20	5310-01-070-2105	96906	MS51967-14
8	21	5310-00-584-5272	96906	MS35338-48
8	22	5310-00-167-0823	88044	AN960-816
8	23	5305-00-071-2072	96906	MS90728-116
8	24	5420-01-062-5595	97403	13211 IE7828-2
8	25	5420-01-071-9058	97403	13211E7828-1
8	26	5420-00-484-5726	97403	1321 IE7827
8	27	5420-01-063-5650	97403	13211 t7816-2
8	27	5420-01-065-6134	97403	13211E7829
8	28	2510-01-168-9886	97403	13211E7821
8	29	2510-00-496-9608	97403	13211E7817-2
8	29	5420-00-495-6012	97403	13211E7817-1
8	30	5305-00-071-2073	96906	MS90728-117
8	31	5420-00-131-4692	97403	13211E7818
8	32	4730-00-182-9086	97403	13211E3212
8	33	4730-01-159-4847	97403	13222E0986-7
8	34	4730-00-288-9773	81343	12-12-140238C
8	35	5305-00-225-3843	96906	MS90728-8
8	36	4730-01-142-8284	97403	13211IE7835

CROSS-REFERENCE INDEXES
FIGURE AND ITEM NUMBER INDEX
STOCK NUMBER

FIG.	ITEM	STOCK NUMBER	FSCM	PART NUMBER
8	37	4730-01-159-4850	97403	13222E0986-9
8	38	4730-00-203-0030	81343	12-12-140239C
8	39	4730-01-009-0981	81343	12-12-140438S
8	40	4730-01-159-4849	97403	13222E0968-11
8	41	5420-01-044-8351	97403	13211E7841
8	41	5945-00-131-4684	97403	13211E7847
8	42	4730-00-796-0496	96906	MS51500A12S
8	43	4730-01-159-4851	97403	13222E0986-12
8	44	5305-00-781-7245	96906	MS35191-323
8	45	4730-01-120-8494	97403	13211E7937
8	46	5310-00-167-0821	88044	AN960-616
8	47	5310-00-637-9541	96906	MS35338-46
8	48	5310-00-732-0559	96906	MS51568-8
8	49	5340-00-462-4143	97403	13211E3139-1
8	50		97403	13211E7838
8	50		97403	13211E7844
8	51	5305-00-903-3640	96906	MS24667-78
8	52	5340-00-290-4503	96906	MS 122088
9	1	5420-01-420-1684	97403	13230E4809
9	2	5340-01-416-3913	97403	13230E4896
9	3	5305-00-225-3845	96906	B1821BH025C100N
9	4	5310-00-929-1807	96906	MS51922-2
9	5	5420-01-420-1685	97403	13230E4899
9	6	5420-01-419-9478	97403	13230E4808
9	7	5340-01-424-5907	97403	13230E6453
9	8	5305-00-916-2345	96906	B1821BH075F200N
9	9	5420-01-419-9485	97403	1323E4893
9	10	5420-01-419-9483	97403	1323E4894
9	11	5310-00-982-6810	96906	MS21044N12
9	12	5305-00-948-0803	96906	B1821BH075F300N
9	13	5340-01-424-5908	97403	13230E6454
9	14	5340-01-424-5909	97403	13230E6455
9	15	2590-01-431-4438	97403	12463645
9	16	5420-01-419-9481	97403	13230E6447
9	17	4730-01-023-7729	59646	MSS SP-03
9	18	4730-01-159-4849	97403	13222E0986-11
9	19	5305-00-068-0510	96906	B1821BH038C100N
9	20	5365-01-393-1243	97403	13230E4810

By Order of the Secretary of the Army:

Official:

CARL E. VUONO
General, United States Army
Chief of Staff

WILLIAM J. MEEHAN II
Brigadier General, United States Army
The Adjutant General

Distribution:

To be distributed in accordance with DA Form 12-37R, Direct Support and General Support requirements for Launcher, Bridge, Tank, M46A5/M60A1 (AVLB).

☆ U. S. GOVERNMENT PRINTING OFFICE: 1989 643-025/80131

RECOMMENDED CHANGES TO EQUIPMENT TECHNICAL PUBLICATIONS



THEN... JOT DOWN THE DOPE ABOUT IT ON THIS FORM. CAREFULLY TEAR IT OUT. FOLD IT AND DROP IT IN THE MAIL.

SOMETHING WRONG WITH THIS PUBLICATION?

FROM: (PRINT YOUR UNIT'S COMPLETE ADDRESS)

Your mailing address

DATE SENT

Date you fill out this form.

PUBLICATION NUMBER

TM5-5420-203-24P

PUBLICATION DATE

MARCH 1988

PUBLICATION TITLE

BRIDGE, ARMORED-VEHICLE LAUNCHED

BE EXACT PIN-POINT WHERE IT IS

PAGE NO	PARA-GRAPH	FIGURE NO	TABLE NO
2-1		2	
5-1		5	
8-1		8	

IN THIS SPACE TELL WHAT IS WRONG AND WHAT SHOULD BE DONE ABOUT IT:

ITEM 10 WILL NOT CONNECT TO ITEM (B) AS SHOWN. ITEM 8 DRAWN WRONG

ITEM 17 NOT SHOWN IN PROPER PLACE

ITEM 2 PARTS LIST. SMR CODE MISSING

SAMPLE

PRINTED NAME GRADE OR TITLE AND TELEPHONE NUMBER

John Smith, Cpt 800-497-9602

SIGN HERE

John Smith

RECOMMENDED CHANGES TO EQUIPMENT TECHNICAL PUBLICATIONS



THEN JOT DOWN THE DOPE ABOUT IT ON THIS FORM. CAREFULLY TEAR IT OUT. FOLD IT AND DROP IT IN THE MAIL.

SOMETHING WRONG WITH THIS PUBLICATION?

FROM (PRINT YOUR UNIT'S COMPLETE ADDRESS)

DATE SENT

PUBLICATION NUMBER

TM5-5420-203-24P

PUBLICATION DATE

November 8, 1988

PUBLICATION TITLE

BRIDGE, ARMORED-VEHICLE LAUNCHED

BE EXACT PIN-POINT WHERE IT IS

PAGE NO

PARA-GRAPH

FIGURE NO

TABLE NO

IN THIS SPACE TELL WHAT IS WRONG AND WHAT SHOULD BE DONE ABOUT IT:

PRINTED NAME GRADE OR TITLE AND TELEPHONE NUMBER

SIGN HERE

FILL IN YOUR
UNIT'S ADDRESS



FOLD BACK

DEPARTMENT OF THE ARMY

OFFICIAL BUSINESS
PENALTY FOR PRIVATE USE \$300

POSTAGE AND FEES PAID
DEPARTMENT OF THE ARMY
DOD 314



TEAR ALONG PERFORATED LINE

Commander
U.S. Army Tank-Automotive Command
ATTN: AMSTA-MB
Warren, Michigan 48397-5000

THE METRIC SYSTEM AND EQUIVALENTS

LINEAR MEASURE

1 Centimeter = 10 Millimeters = 0.01 Meters = 0.3937 Inches
 1 Meter = 100 Centimeters = 1000 Millimeters = 39.37 Inches
 1 Kilometer = 1000 Meters = 0.621 Miles

WEIGHTS

1 Gram = 0.001 Kilograms = 1000 Milligrams = 0.035 Ounces
 1 Kilogram = 1000 Grams = 2.2 Lb.
 1 Metric Ton = 1000 Kilograms = 1 Megagram = 1.1 Short Tons

LIQUID MEASURE

1 Milliliter = 0.001 Liters = 0.0338 Fluid Ounces
 1 Liter = 1000 Milliliters = 33.82 Fluid Ounces

SQUARE MEASURE

1 Sq. Centimeter = 100 Sq. Millimeters = 0.155 Sq. Inches
 1 Sq. Meter = 10,000 Sq. Centimeters = 10.76 Sq. Feet
 1 Sq. Kilometer = 1,000,000 Sq. Meters = 0.386 Sq. Miles

CUBIC MEASURE

1 Cu. Centimeter = 1000 Cu. Millimeters = 0.06 Cu. Inches
 1 Cu. Meter = 1,000,000 Cu. Centimeters = 35.31 Cu. Feet

TEMPERATURE

$\frac{5}{9}(F - 32) = C$
 212° Fahrenheit is equivalent to 100° Celsius
 90° Fahrenheit is equivalent to 32.2° Celsius
 32° Fahrenheit is equivalent to 0° Celsius
 $\frac{5}{9}C + 32 = F$

APPROXIMATE CONVERSION FACTORS

TO CHANGE	TO	MULTIPLY BY
Inches	Centimeters	2.540
Feet	Meters	0.305
Yards	Meters	0.914
Miles	Kilometers	1.609
Square Inches	Square Centimeters	6.451
Square Feet	Square Meters	0.093
Square Yards	Square Meters	0.836
Square Miles	Square Kilometers	2.590
Acres	Square Hectometers	0.405
Cubic Feet	Cubic Meters	0.028
Cubic Yards	Cubic Meters	0.765
Fluid Ounces	Milliliters	29.573
Pints	Liters	0.473
Quarts	Liters	0.946
Gallons	Liters	3.785
Ounces	Grams	28.349
Pounds	Kilograms	0.454
Short Tons	Metric Tons	0.907
Pound-Feet	Newton-Meters	1.356
Pounds per Square Inch	Kilopascals	6.895
Miles per Gallon	Kilometers per Liter	0.425
Miles per Hour	Kilometers per Hour	1.609

TO CHANGE	TO	MULTIPLY BY
Centimeters	Inches	0.394
Meters	Feet	3.280
Meters	Yards	1.094
Kilometers	Miles	0.621
Square Centimeters	Square Inches	0.155
Square Meters	Square Feet	10.764
Square Meters	Square Yards	1.196
Square Kilometers	Square Miles	0.386
Square Hectometers	Acres	2.471
Cubic Meters	Cubic Feet	35.315
Cubic Meters	Cubic Yards	1.308
Milliliters	Fluid Ounces	0.034
Liters	Pints	2.113
Liters	Quarts	1.057
Liters	Gallons	0.264
Grams	Ounces	0.035
Kilograms	Pounds	2.205
Metric Tons	Short Tons	1.102
Newton-Meters	Pound-Feet	0.738
Kilopascals	Pounds per Square Inch	0.145
Kilometers per Liter	Miles per Gallon	2.354
Kilometers per Hour	Miles per Hour	0.621

